

Boomerang **SPRINT**

Aerobatic Sport / Trainer Jet for 12 to 22 Lb. Thrust turbines
Almost ready to fly. Speed range from 18 to 150 MPH.

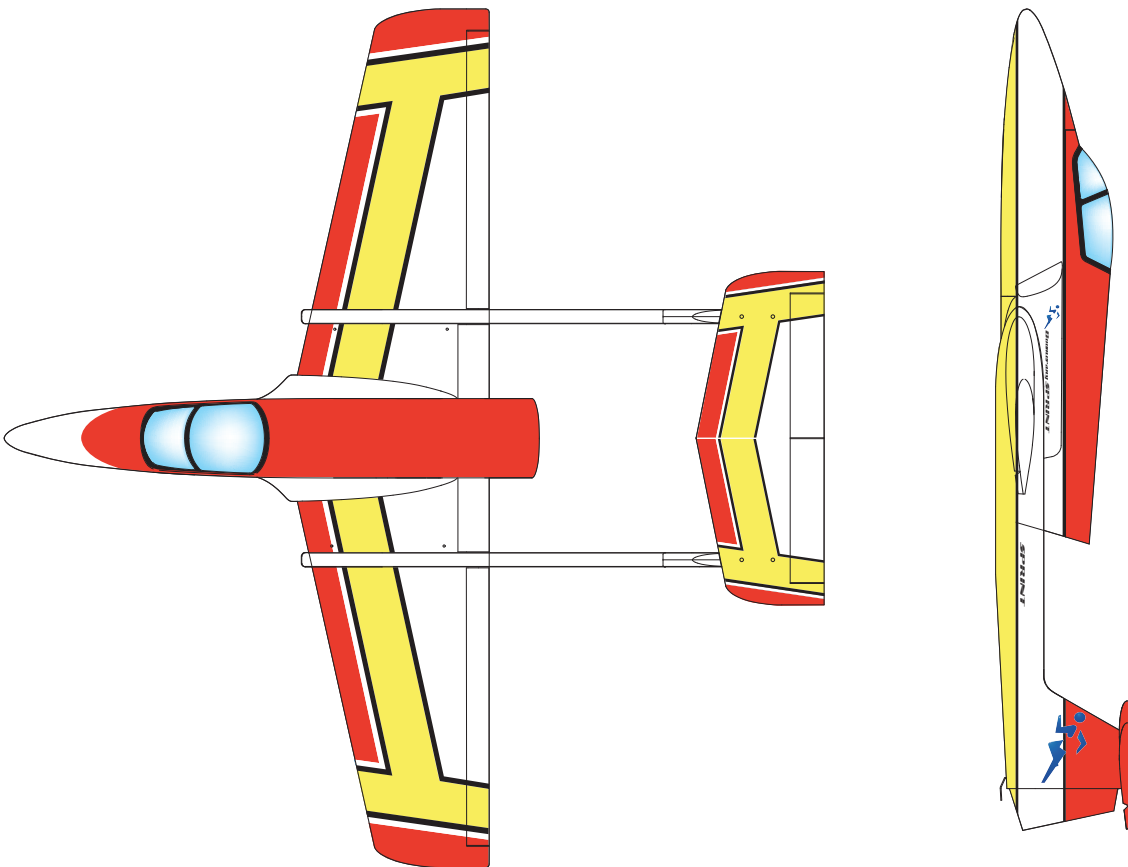

Wingspan..... 75.5" (1920mm)
Length..... 73" (1850 mm)
Weight 14lb.(6.35kg) Dry.
Radio..... 5 to 7 Channels.

Designer Alan Cardash
Boomerang RC Jets, LLC.
Website www.boomerang-RC-jets.com

SAFETY PRECAUTIONS

The SPRINT turbine model is designed for experienced modellers. This model is not recommended for beginners to R/C flying and should not be attempted by those with insufficient building and flying experience. This manual is for guidance only. If you are unsure of any model building techniques, seek help from an experienced model builder or contact Boomerang RC Jets LLC. for assistance. Jet models are dangerous if construction is carelessly or incorrectly carried out. As the building assembly of this kit is out of our control after point of sale, no liability is accepted by Boomerang RC Jets LLC. for any accident or loss, however caused. Purchase of this kit implies acceptance of these conditions by the purchaser. To decline these terms, return the unused kit to your supplier for full refund.

BEFORE YOU BEGIN CONSTRUCTION

Some of the Additional items required to complete this kit;-

Suggested Servos;-

Ailerons;- 2 High torque servos (5+Kg).

Elevator;- 1 High torque servos (9+Kg).

Rudders;- 2 High torque servos (5+Kg).

Flap;- 1 High torque servo (6+Kg)

Steering;- 1 medium power standard Servo.

Retracts and brakes;- Standard servos or electronic valves.

Extension leads to servos.

2 off. 600mm. for rudders used in the booms.

"Y Link" for rudders used in center wing.

2 off. 600mm. used in center wing for ailerons. (2 channels)

2 off. 100mm. for ailerons in outer wing panels.

"Y link" if using only one channel for ailerons.

1 of 900mm. used along left hand boom to elevator

1 of 80mm. used in tailplane (stabiliser) for elevator.

You will find extra covering is in the kit to use for detail finishing or for adding your own touches to the colour trim.

Boomerang Jets own Sullivan Custom fit fuel tank is recommended and you should use a Hanson Super Trap or similar UAT bubble trap. These can be purchased from your Boomerang dealer.

The retracts used in the prototypes are Springair 101 HD, but any make of lightweight, heavy duty retracts will be suitable. (3/16" or 5mm. wire legs). Wheels 63mm. (2.5") mains, with 55mm. (2.25") noseleg. Brakes optional. Sprint will come to a stop and stand on a runway with the turbine idling, without brakes but for safety, brakes are recommended. these are mandatory in the USA.

Use of a whip antenna to your FM or PCM radio is highly recommended or if using 2.4 Ghz a main receiver with two satellites.

This kit is designed for turbines from 12 to 22 lbs of thrust. Do not use a larger turbine! Keeping the weight as light as possible will give the sparkling performance that Boomerang designs are noted for.

Optional;- If you wish to add to or modify the trim at any time, this model is covered in Profilm. (Oracover).

Note the Symbols used throughout these instructions.



Assemble left and right sides the same way.



Not supplied



Drill holes to the specified diameter (here: 2mm. shown).



Cut off shaded portion.



Apply epoxy glue.



Pay close attention here!



Ensure smooth non-binding movement while assembling.



Apply instant glue (CA glue, super glue).



Warning! Do not overlook this symbol!

1 Centre Wing

Centre Wing

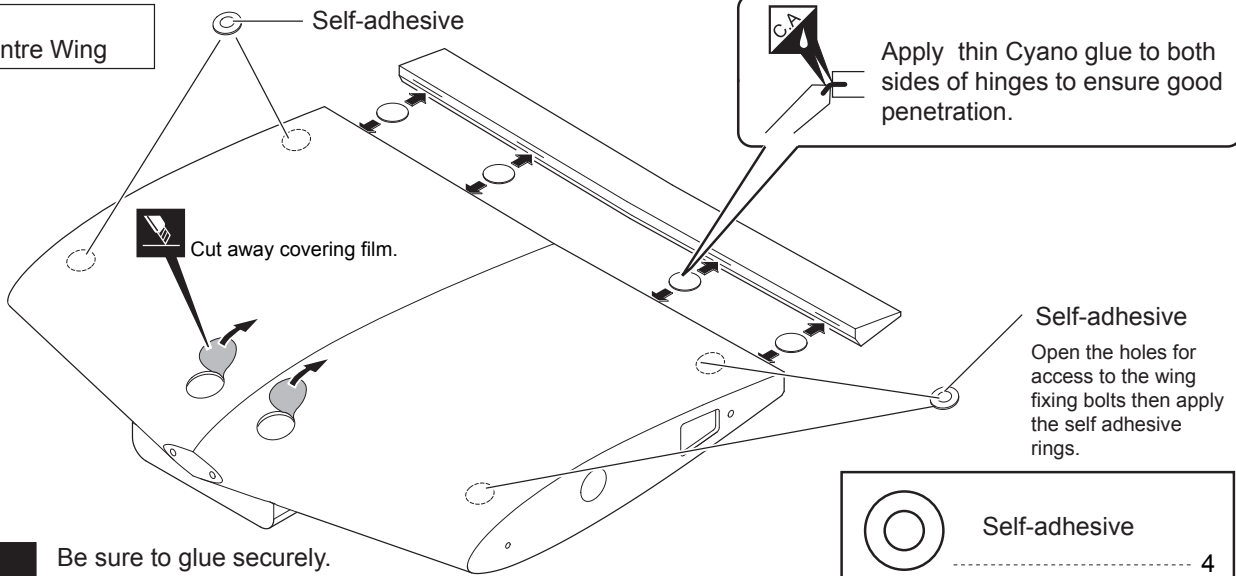

Warning!

Be sure to glue securely. This is Vital for safe flying!

2 Typical Servo Mount

Typical Servo Mount

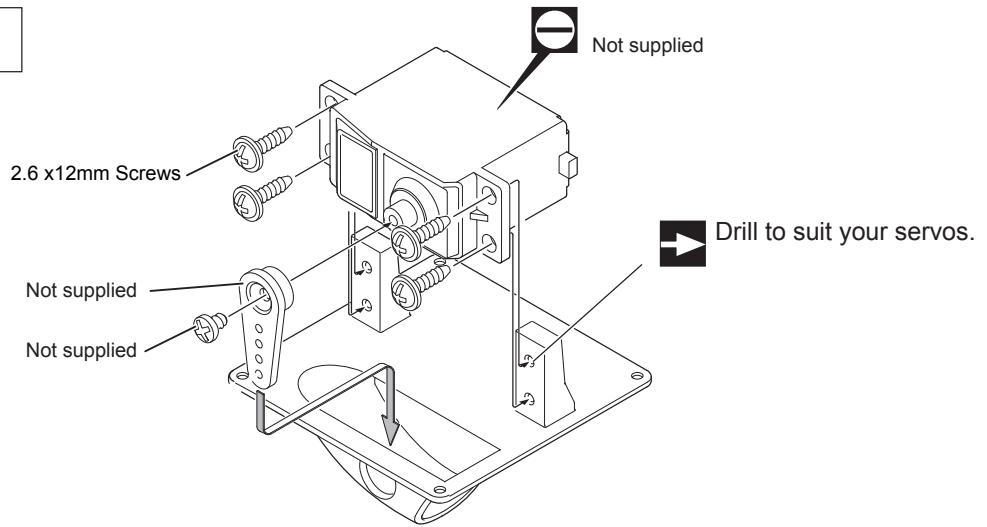

3 Flap Servo Installation

Flap Servo Installation

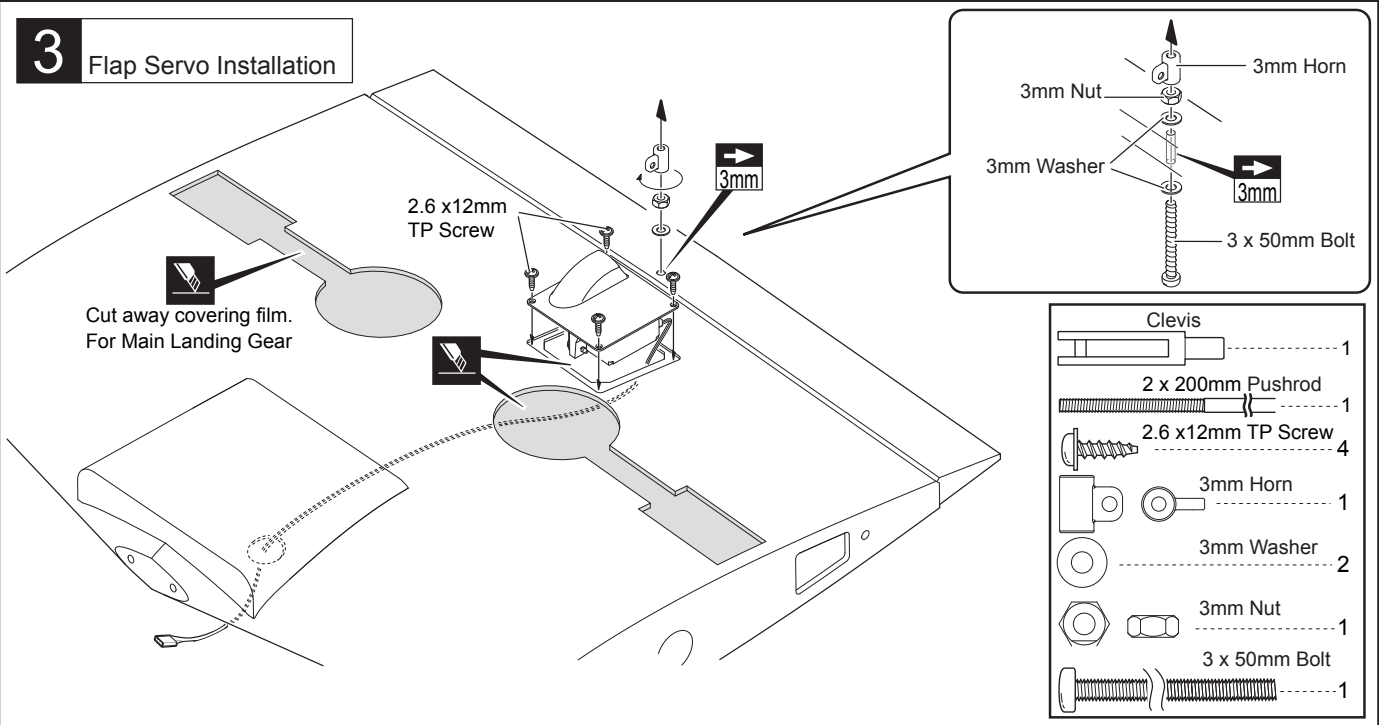

4

Pushrods

To Make the Pushrods to the length required;-

- (1) Make a 90 degree bend in the wire at the length required to meet the output hole in the servo arm with the servo centred.

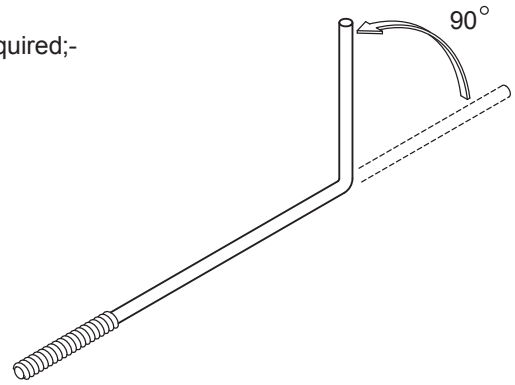

- (2) Now make a second bend off at 90 degrees to the first one, left or right, in the wire at approx. 3mm away from the first bend.

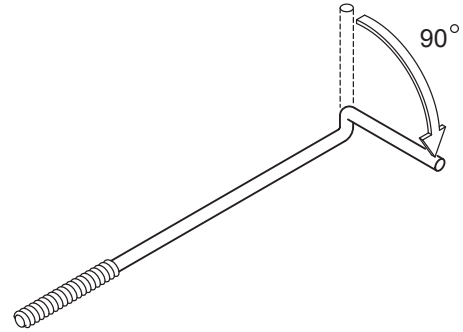

- (3) Straighten the wire by gripping each side of the "Z" bend with pliers and slowly turning until the ends are in line. Now cut off the excess wire. The output hole in the servo arm may have to be drilled out to accommodate the "Z" bend wire passing through it. Adjustment of the pushrod length is carried out by adjusting the clevis along the threaded part of the pushrod.

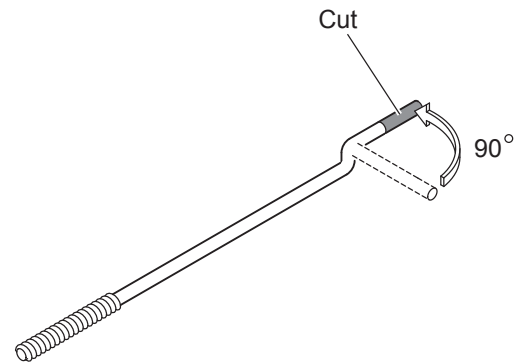

An extra pushrod is supplied to allow for possible error.

5

Flap control



Assemble left and right sides the same way.

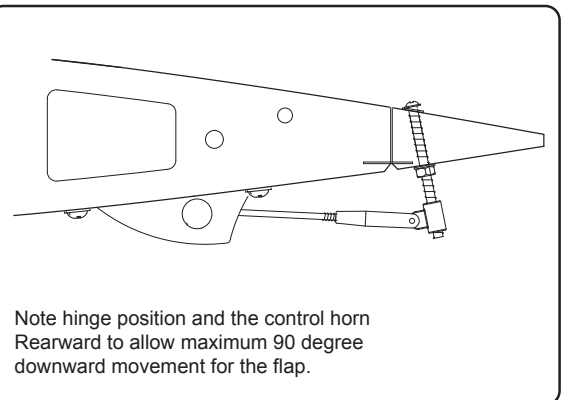
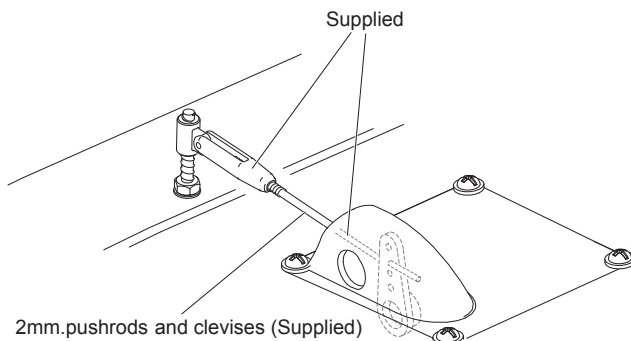

6 Main Landing Gear

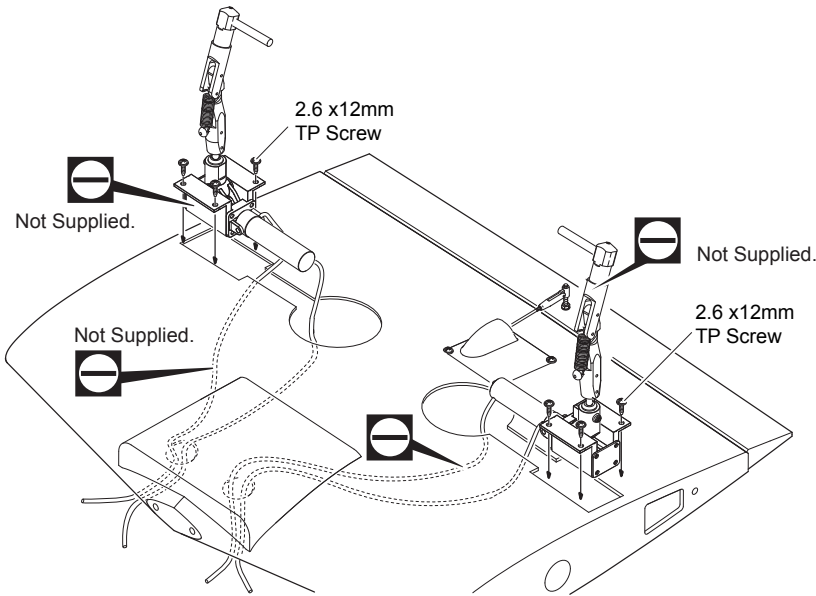

For Retractable landing gear

- ➔ ● Requires some modification on main gear cover.
- The main leg retracts should be fitted about 1/2" inboard of the centre wing tip.

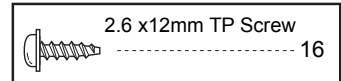

7 Main Landing Gear

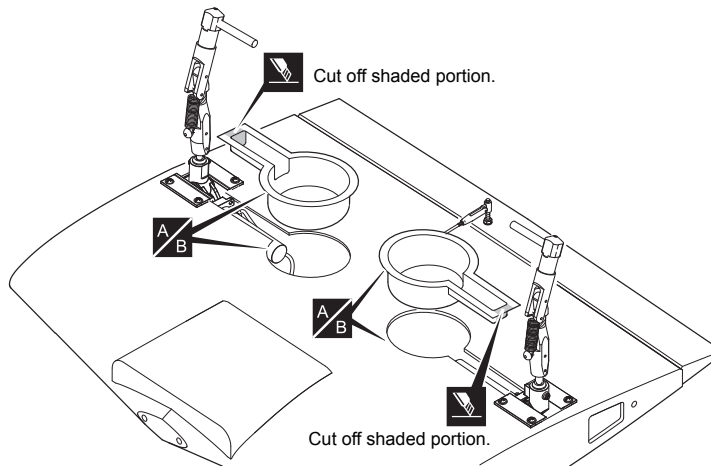

- ➔ For Retractable landing gear
NOTE;
Do not fix plastic wheel wells until the servo wires and air lines are in place.
Level off the surface around the retract units.

8 Main Landing Gear

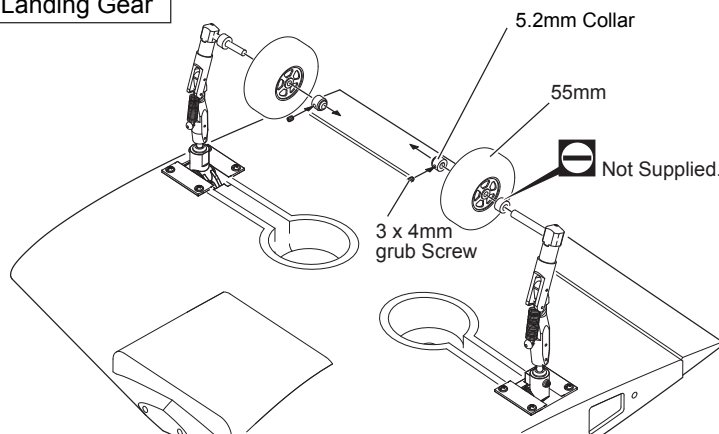

The height of the landing gear should be approximately as follows;
Noseleg 11cms. and mains 12cms.
from underside surfaces to the wheel axles.

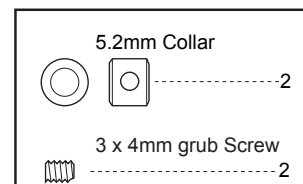

9

Centre Wing

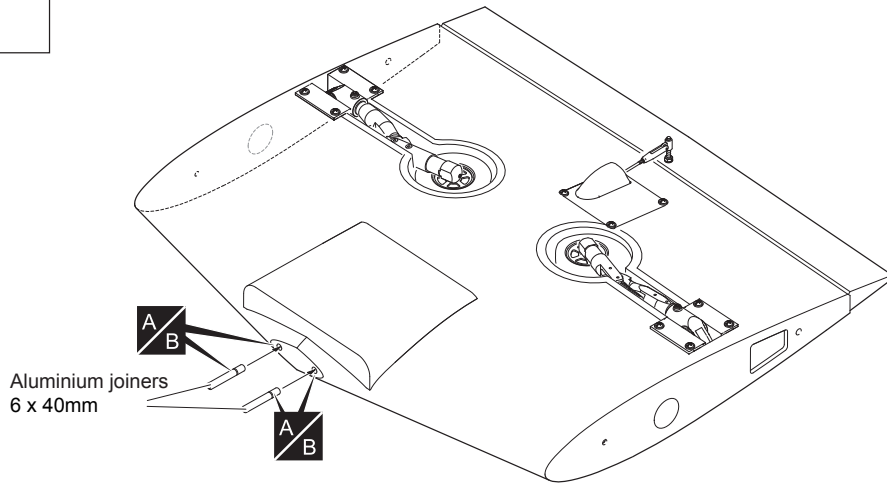

Aluminium joiners
6 x 40mm

Aluminium joiner 6 x 40mm



2

10

Outer wing panel

L/R Assemble left and right sides the same way.

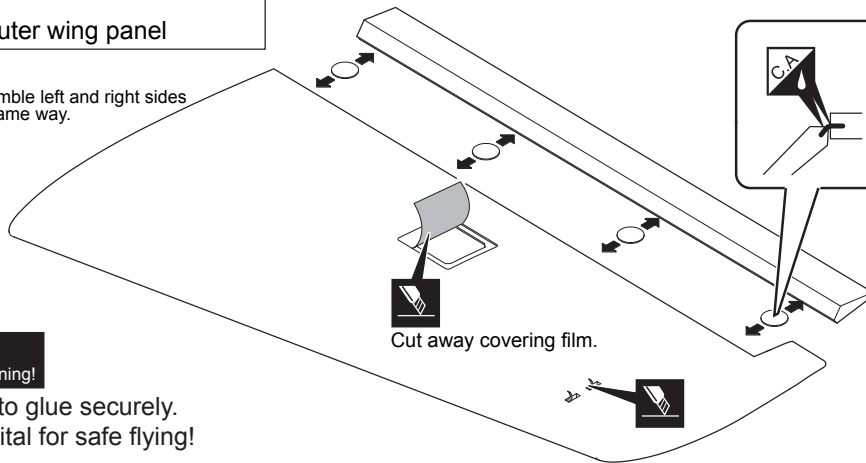

Be sure to apply instant type CA glue to both sides of each hinges. (low viscosity type)

When cutting away the film, for the servo mount leave a generous overhang to allow for the strong shrinkage of the Profilm (Orocover) when you finally iron it back in place.



Warning!

Be sure to glue securely. This is Vital for safe flying!

11

Aileron Servo installation

L/R Assemble left and right sides the same way.

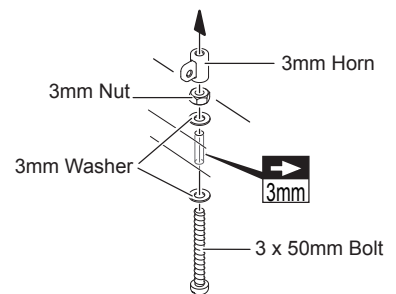
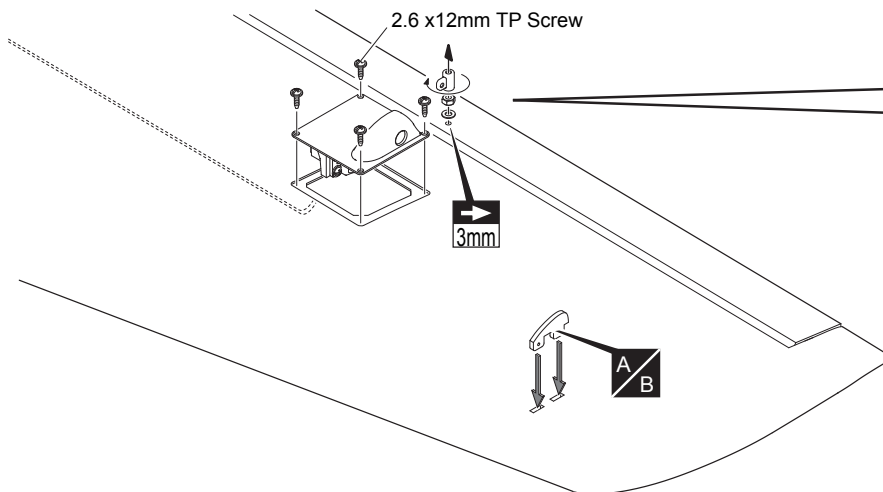

Apply thin cyano top and bottom and immediately tighten the 3mm. nut to prevent the 3mm. bolt rotating.

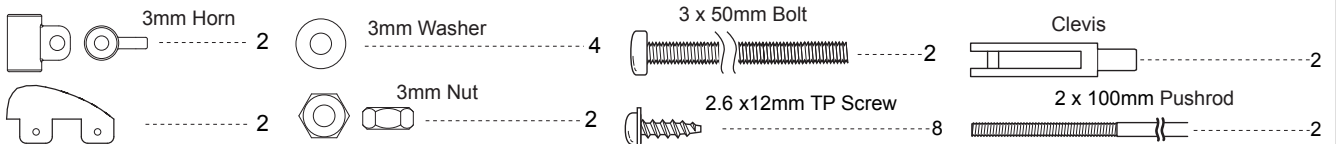

12 Aileron Servo installation

 Assemble left and right sides the same way.

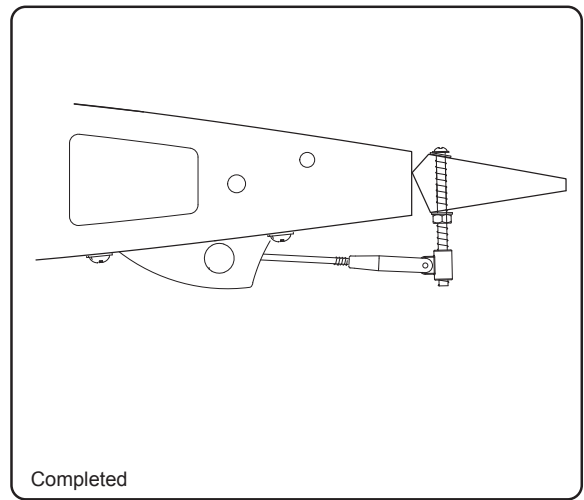
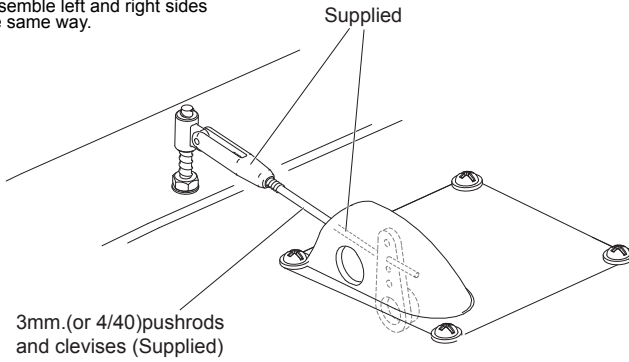

13 Outer wing

 Assemble left and right sides the same way.

Screw in the 8 X 285 mm alloy rods.

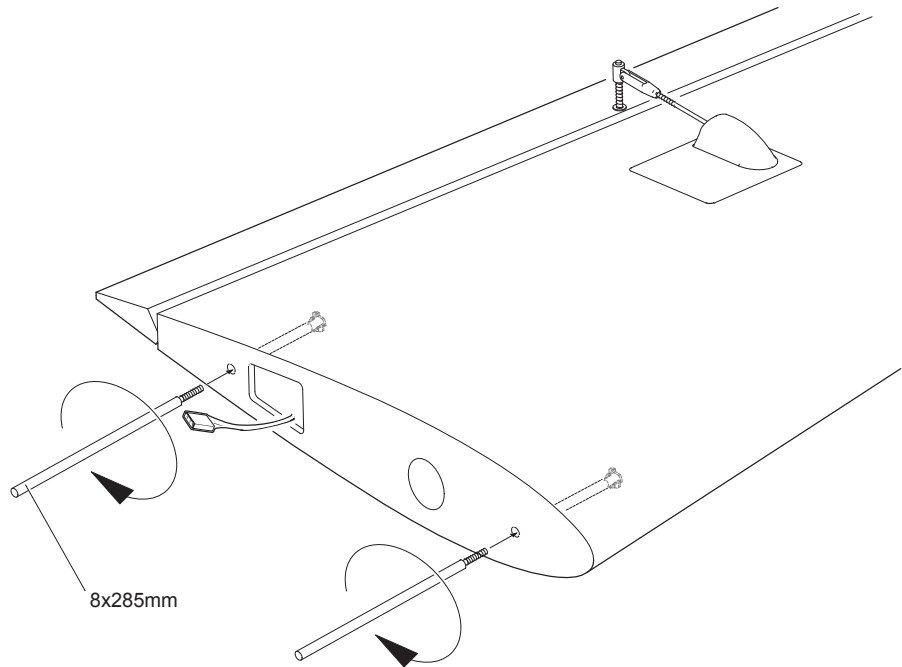

14 Rudder Servo installation

 Assemble left and right sides the same way.

500mm. servo extension wires to rudder servos in both booms. Also 700mm. extension wires to Elevator Servo in Left hand boom only .(not supplied)

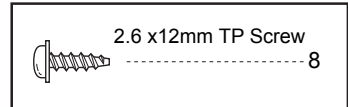
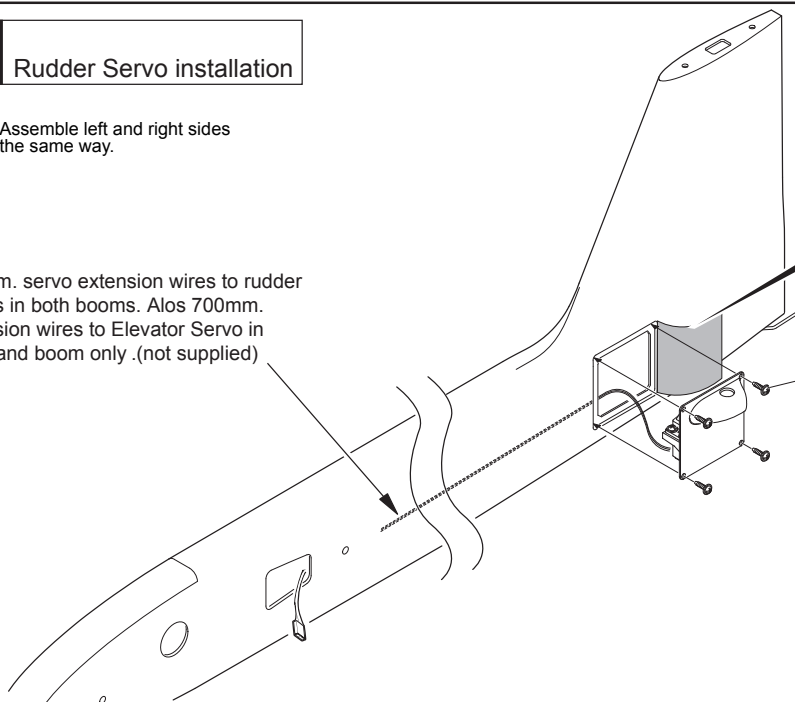

In order to save weight at the tail end, you can use "Midi" servos for the rudders. If you do this make up 6mm (1/4") liteply plates to raise the smaller servos and reduce the standard spacing of the servo mountings supplied. Remember to allow for the shrinkage of the covering when cutting away for the servo mounts.

15 Rudder installation

L R Assemble left and right sides the same way

The tailskids are designed to swivel freely.

- 3mm Nut 2
- 3 x 50mm Bolt 2
- 3mm Horn 2
- 3mm Washer 4

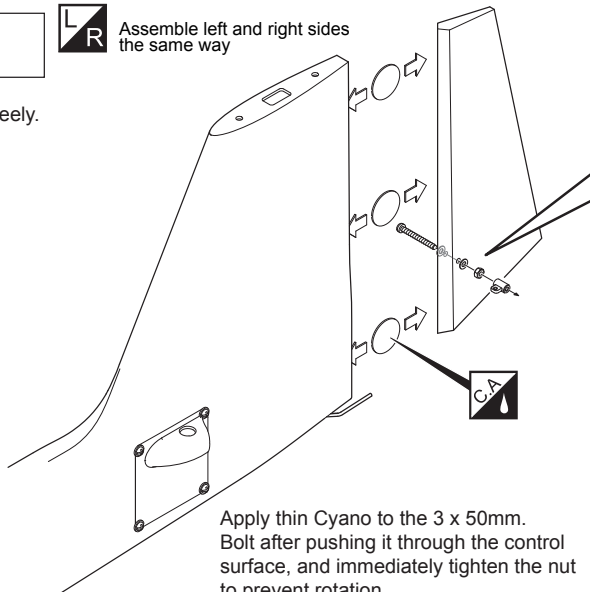

Apply thin Cyano to the 3 x 50mm. Bolt after pushing it through the control surface, and immediately tighten the nut to prevent rotation.

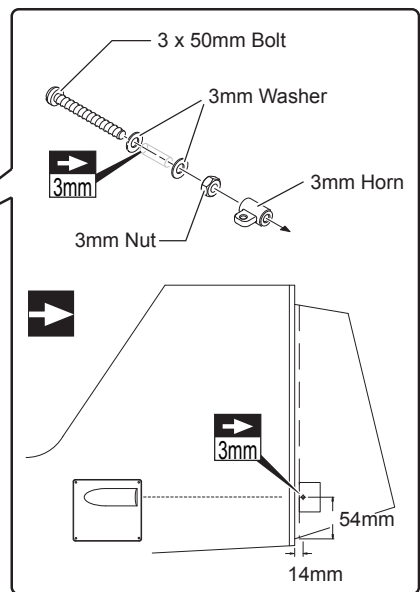

16 Rudder installation

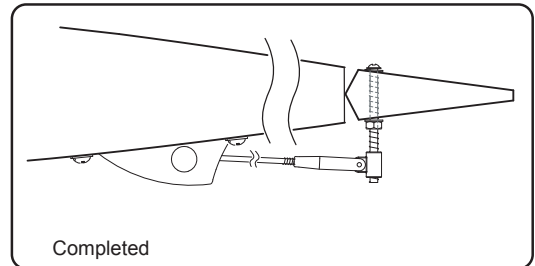
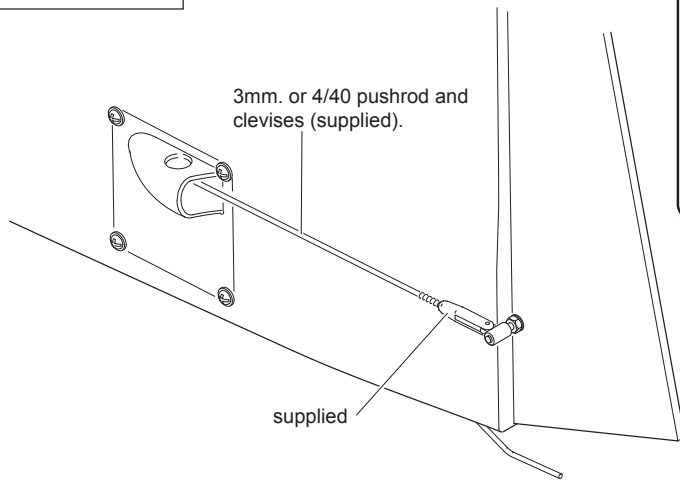

- Clevis 2
- 2 x 200mm Pushrod 2

L R Assemble left and right sides the same way.

17 Tailplane/Stab

Lightly iron the covering through a cloth with a warm iron before cutting away covering film for the servo mount. Leave 3mm overhang all round the servo mounts as per the wings.

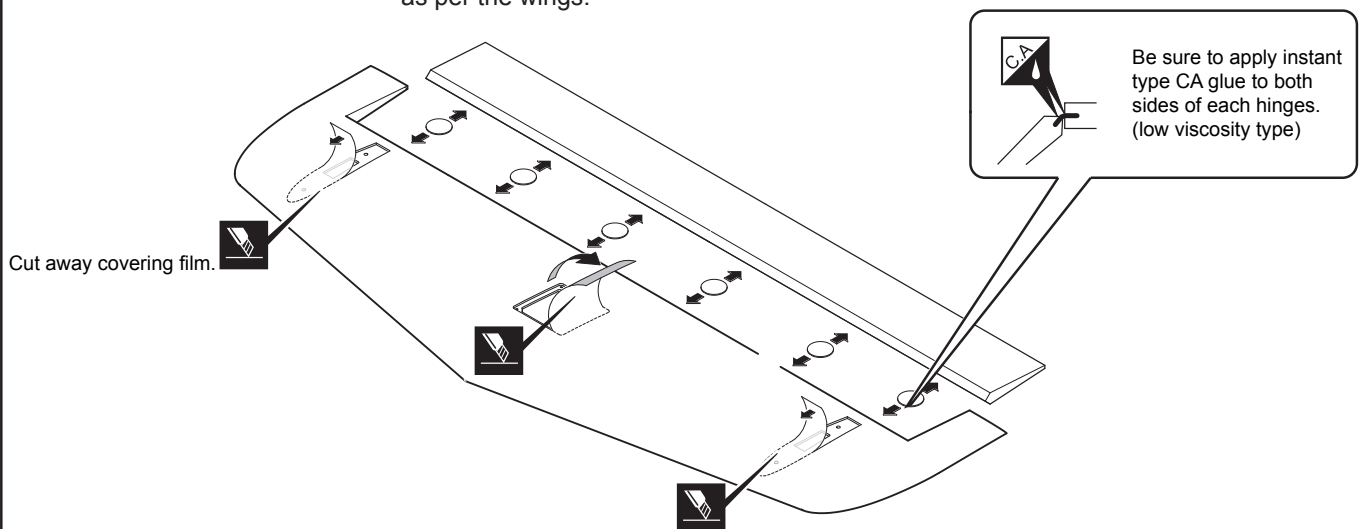

18 Elevator Servo installation

Apply thin Cyano to the 3 x 50mm. Bolt after pushing it through the control surface, and immediately tighten the nut to prevent rotation.

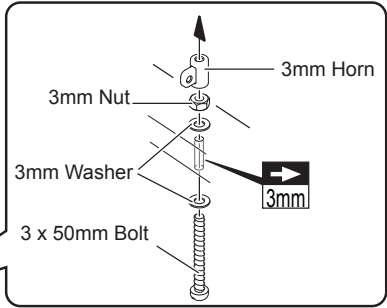
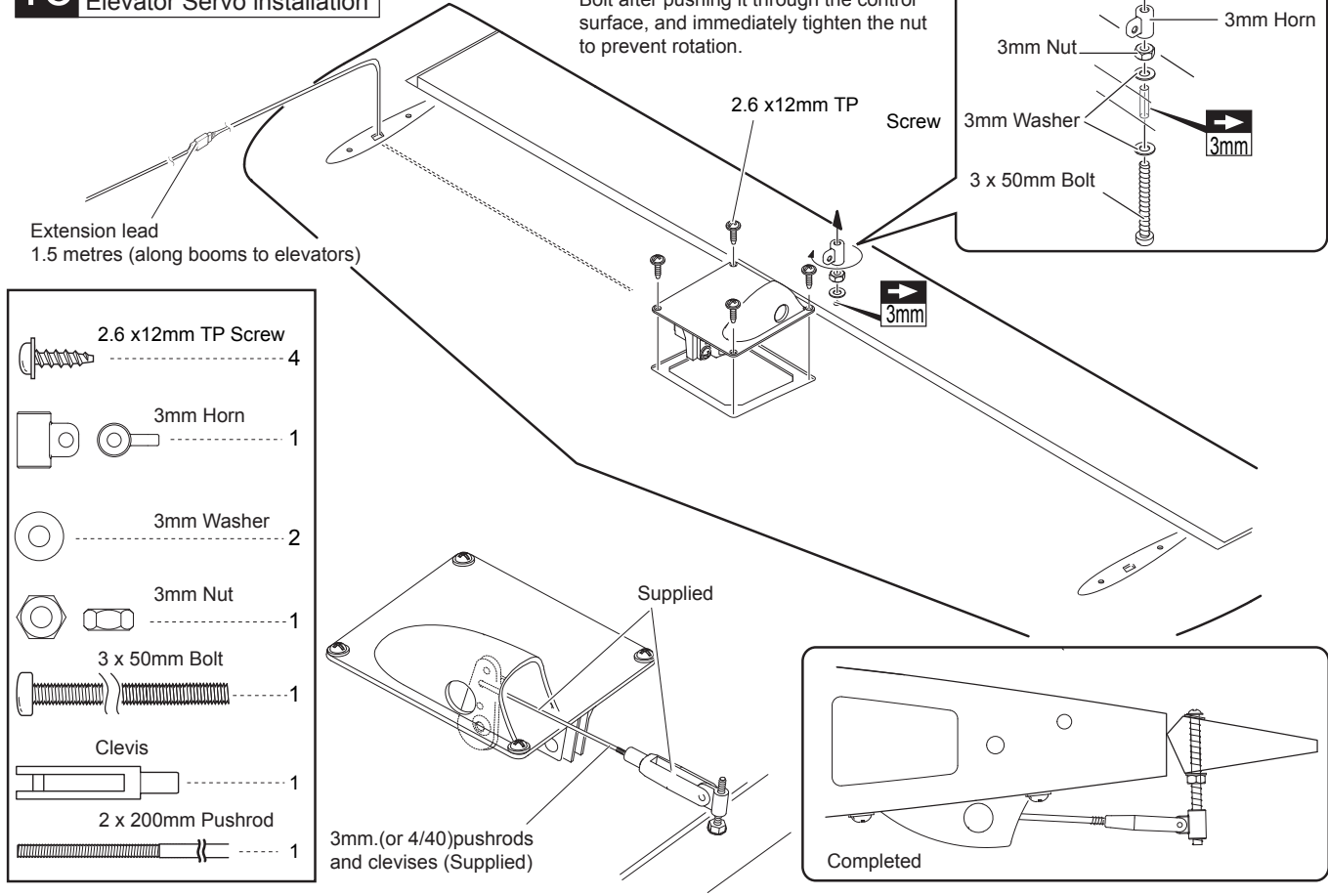

- 2.6 x12mm TP Screw ----- 4
- 3mm Horn ----- 1
- 3mm Washer ----- 2
- 3mm Nut ----- 1
- 3 x 50mm Bolt ----- 1
- Clevis ----- 1
- 2 x 200mm Pushrod ----- 1

19 Final Assembly

Adjusting the Carbon Fibre Spars.

If it is necessary to adjust the fit of the C/F spars within the wings, apply the Heatshrink supplied to the spars as shown. The spars should be "snug", but not tight.

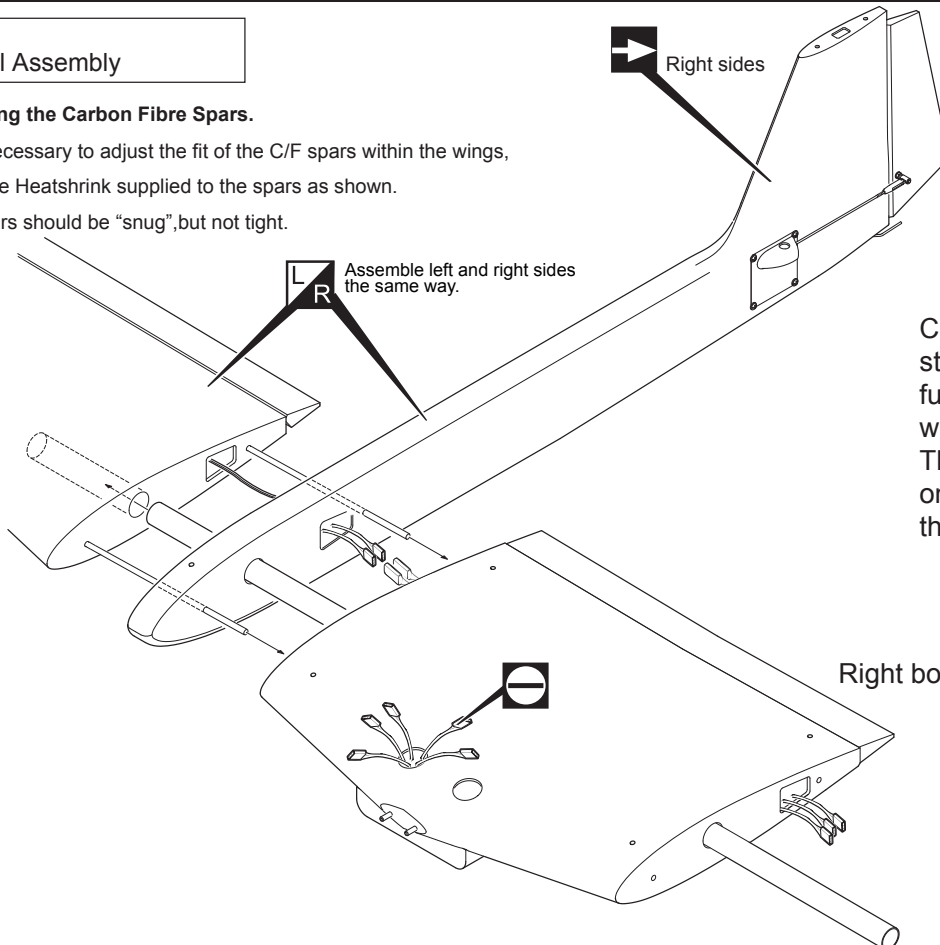

Cut away the plywood stays across the fuselage and the hatch where they are marked. These are for packing only, not structural to the airframe.

20 Wing Locking

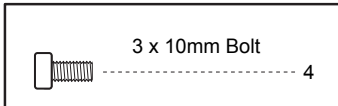
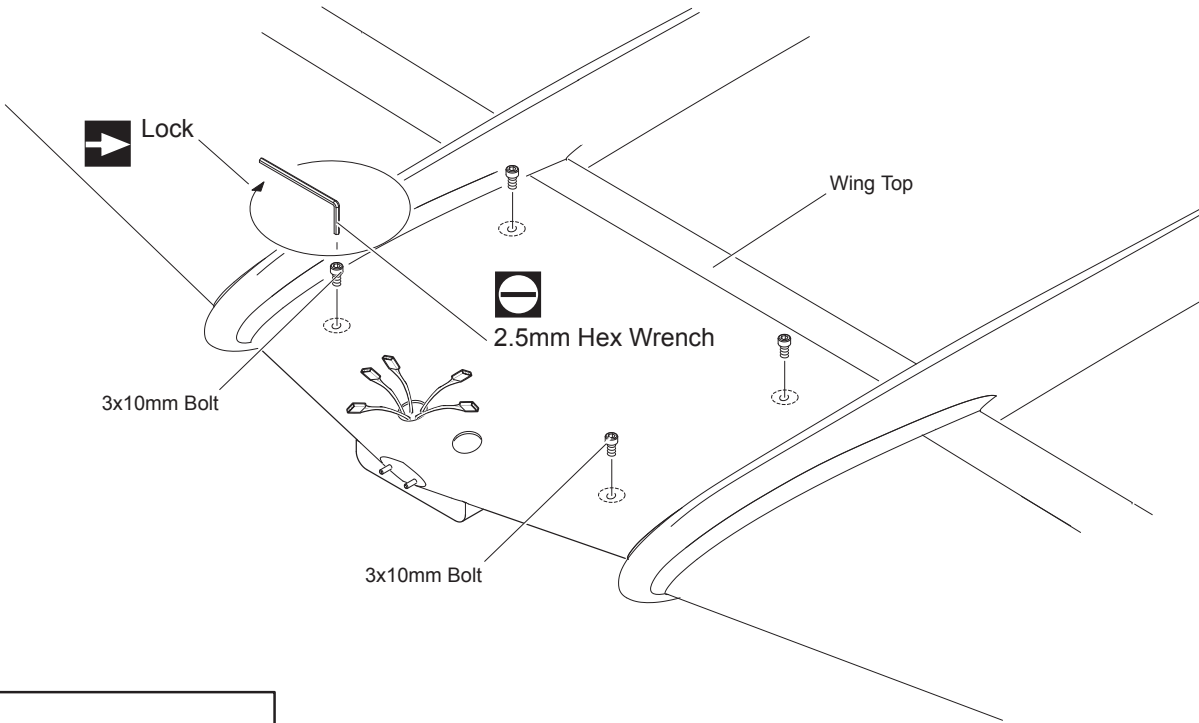

21 Tail Assembly

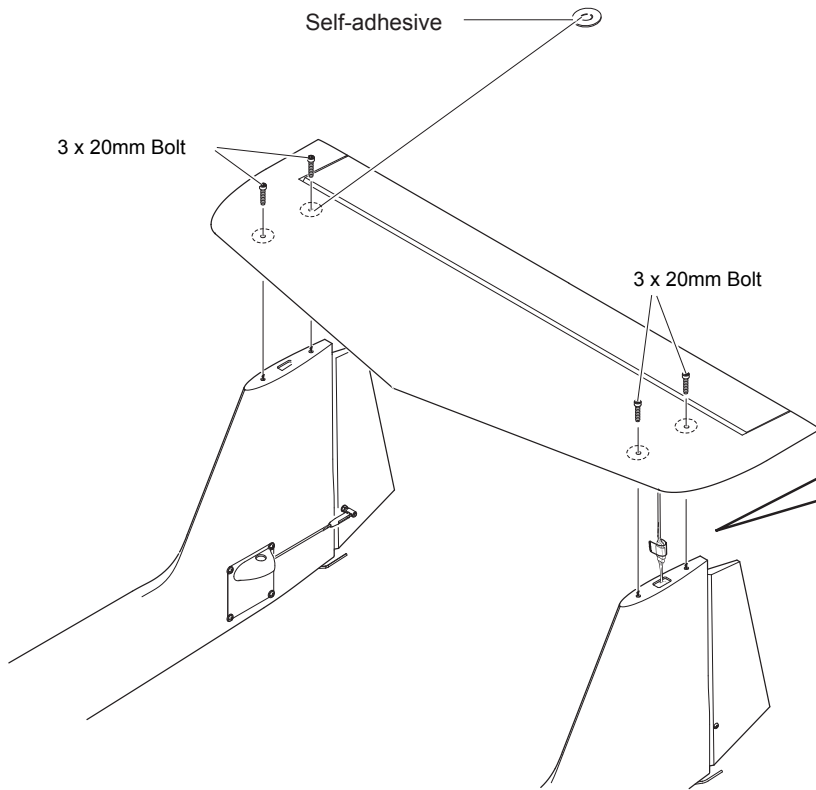

Decrease size of top exit hole after wires are through to prevent the connector falling inside the fin.

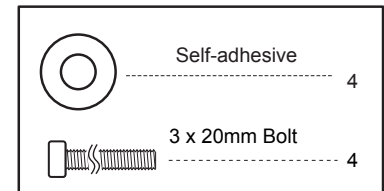

22 Noseleg Servo

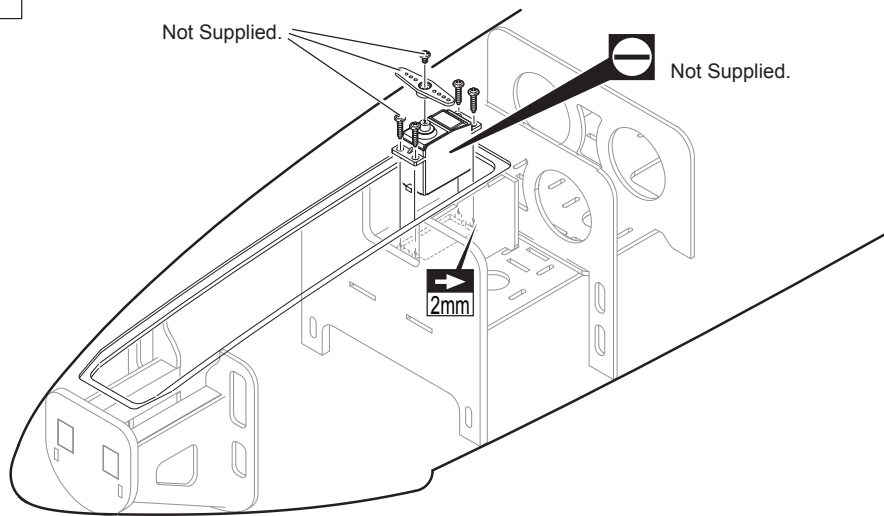

23 Noseleg Mounting

For Retractable landing gear.



“Trim the Cover Plate to clear the leg.”

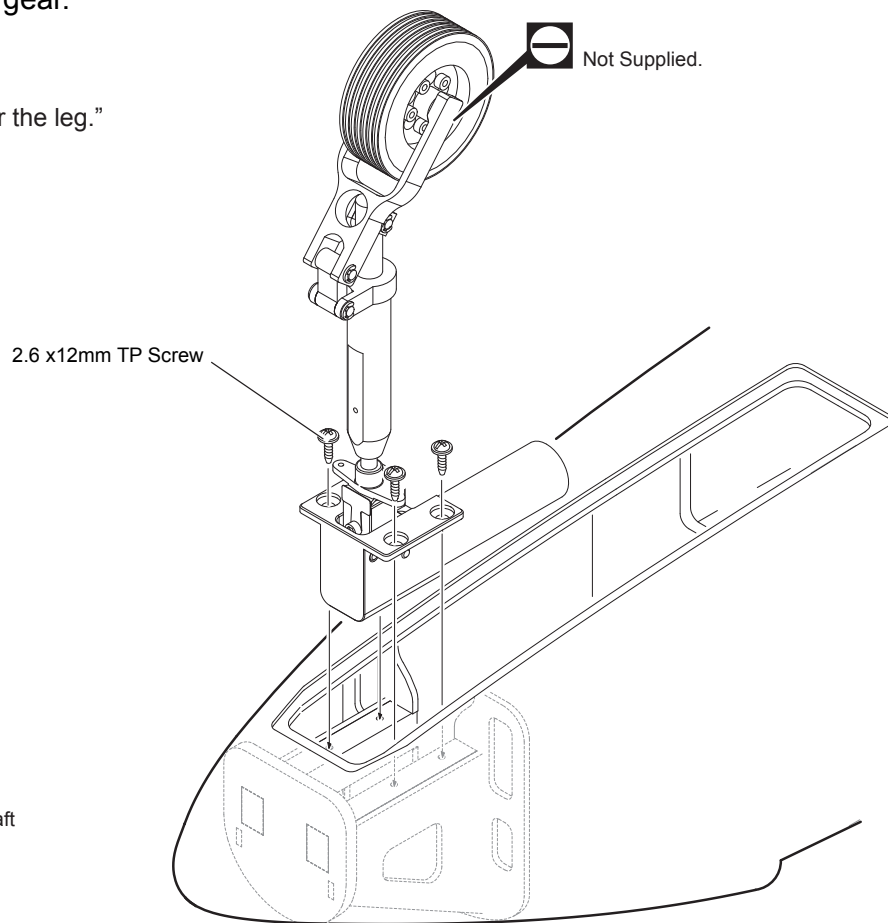

Cut away part of the former at the rear of the rails to allow the retract unit steering arms to drop cleanly aft of the retract mounting rails.

The nose leg length adjusted to give a degree or two negative incidence or slightly nose down attitude when Intro is standing on a level surface. This will be easily overcome on take off by the elevator authority and will also help to eliminate bounce on landing.

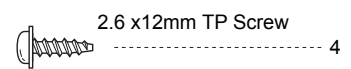

24 Noseleg

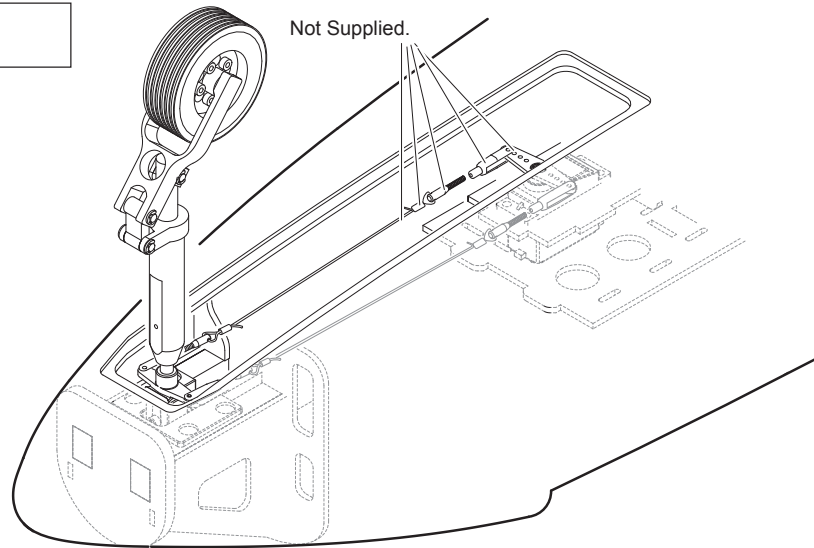

25 Noseleg Cover Plate

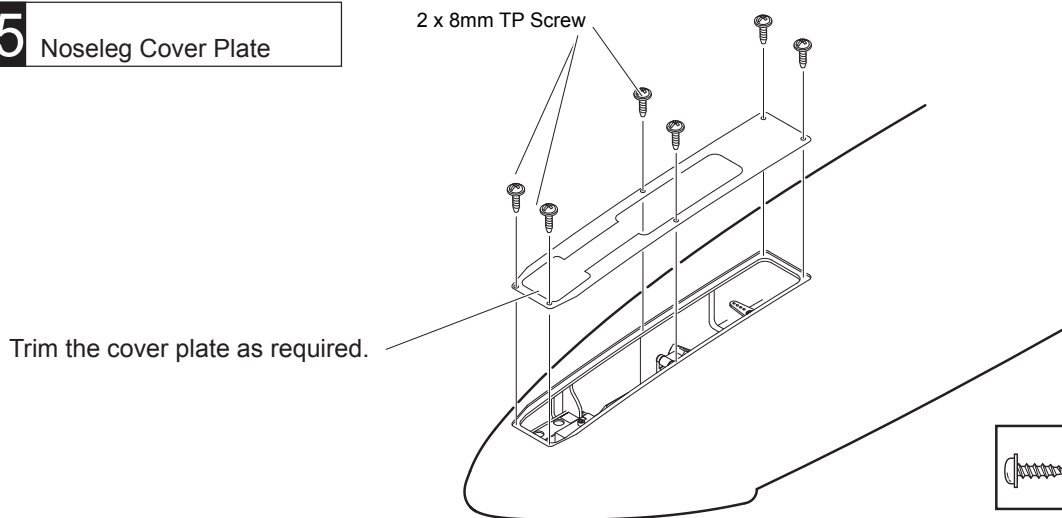



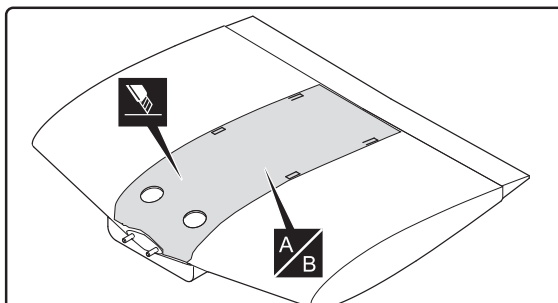

	2 x 8mm TP Screw	6
---	------------------	---

26 Fuselage/Wing joining

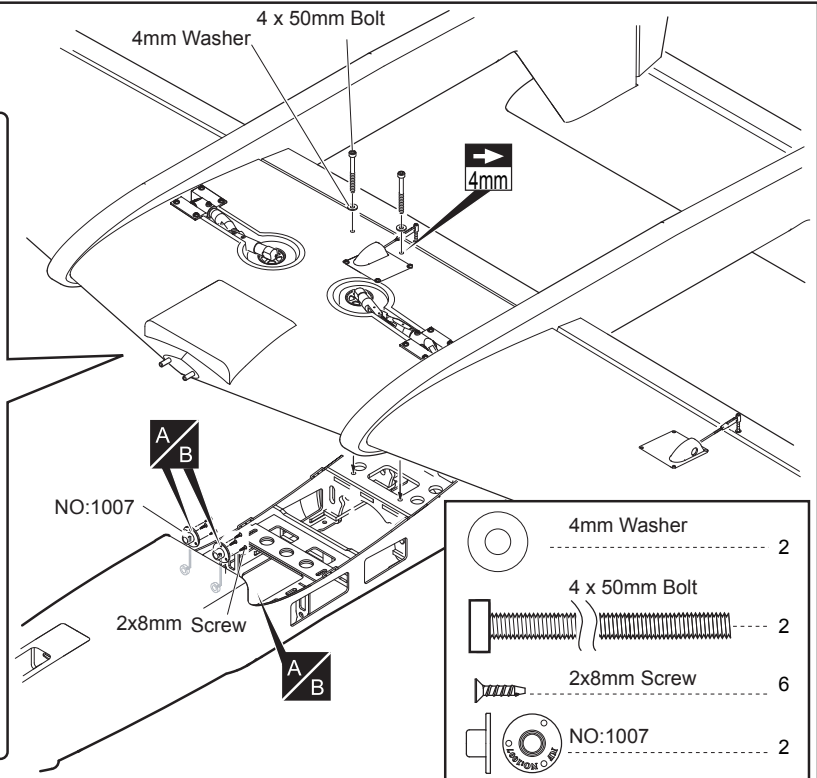

Cut away the covering from the slots on top of the centre wing. Place the fuselage wing seat tabs into the slots. Mark the wingtop covering along each side where the fuselage sits on the wing. Remove the fuselage and carefully cut through the covering without damaging the balsa and strip off the film between the marks you have made. Now strip the covering carefully from the underside edge only of the fuselage wing seat. Before finally gluing the wing to the fuselage, drill and inset the alloy dowels to the front of the wing. These will slip into the parts No. 1007 supplied which should be epoxied to the former using these dowels to adjust their position. Drill a 4mm hole through the wing and plywood plate in the fuselage near the trailing edge and fit the blind nuts on the topside of the ply. When satisfied with the fit, epoxy the fuselage to the wing and tighten the bolts moderately with washers to give a strong wing fix. The wing is not designed to be removable.



	4mm Washer	2
	4 x 50mm Bolt	2
	2x8mm Screw	6
	NO:1007	2

27 Air Intakes

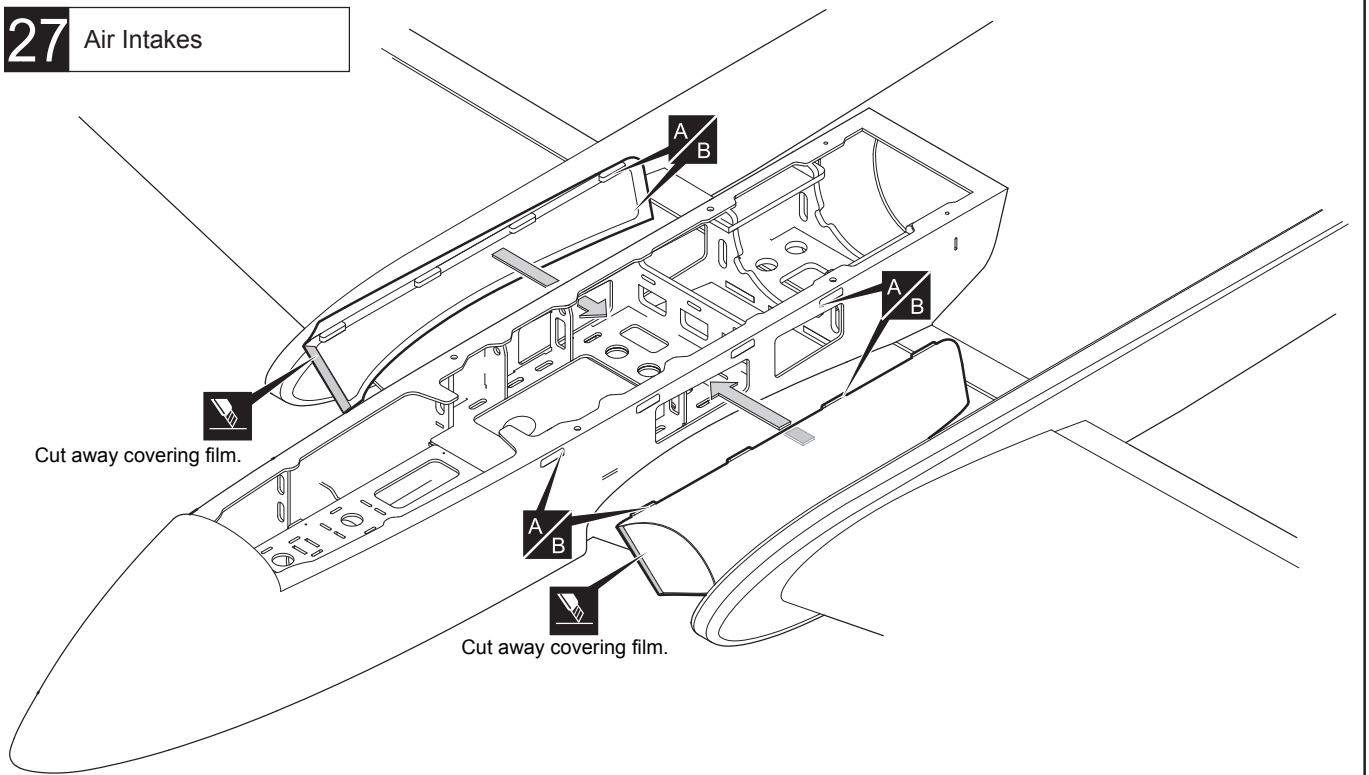

Clean up the front opening of the air intakes as necessary. After carefully stripping away covering film from the small cutouts in the upper fuselage use the air intakes as a guide to how much covering to remove from each side of the fuselage, opening up the airflow openings each side and leaving a bare wood gluing surface just a few mm. smaller than the intakes all around ready to fix the intakes using thick CA glue. The air intake is glued to the fuselage only, not to the wing.

28 Fuel Tank etc

A custom Sullivan 3.7 litre fuel tank made for this kit is available from your Boomerang Jets dealer. Otherwise it is possible to fit any container from 2 litres up by modifying the fuselage formers as required. Ensure that the tank is well secured by using long cable tie wraps through the formers. Do not simply depend on the tank bay floor for this. A full tank of fuel weighs anything up to 8 Lbs (4 Kilos) and in a negative G manoeuvre can exert considerable upward pull.

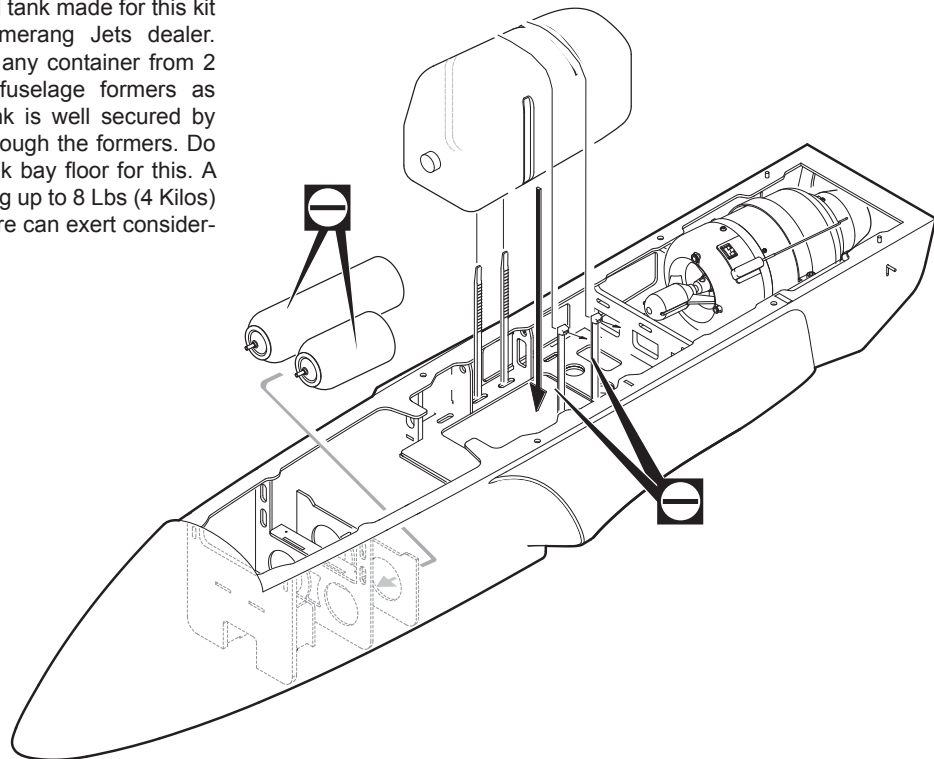

29 Canopy fix

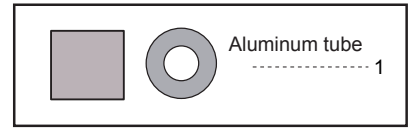
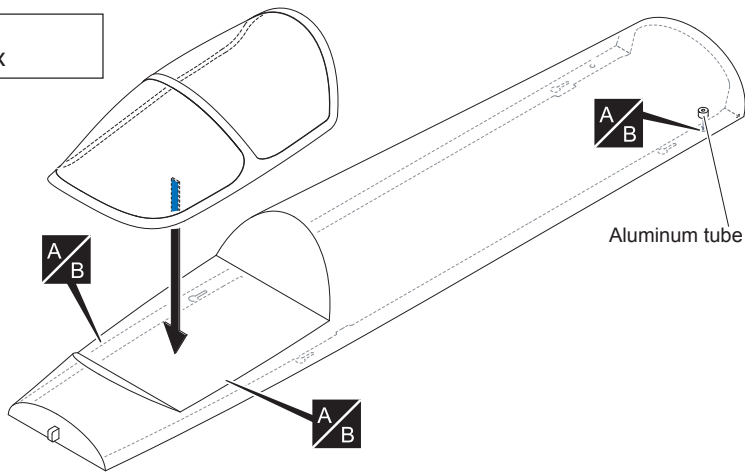

30 Check Hatch fit

Trim the hatch latch and if necessary adjust the front peg to achieve a good sliding fit. A small smear of grease on the slots & alloy buttons will help the hatch to slide easily into place.

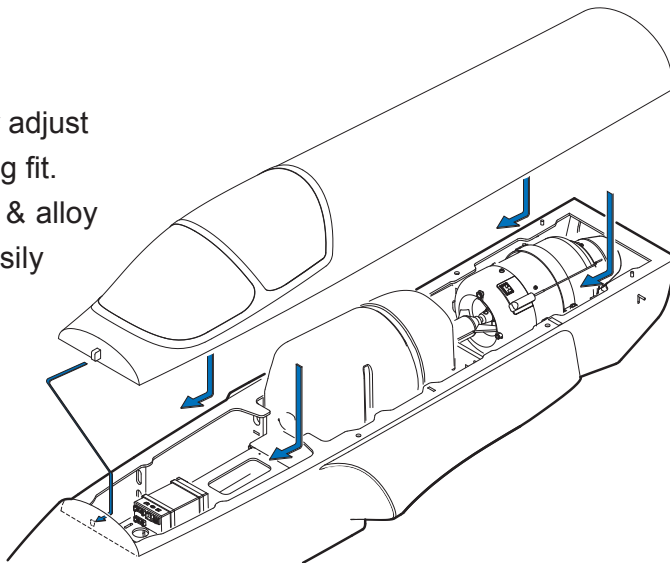

31 Decals

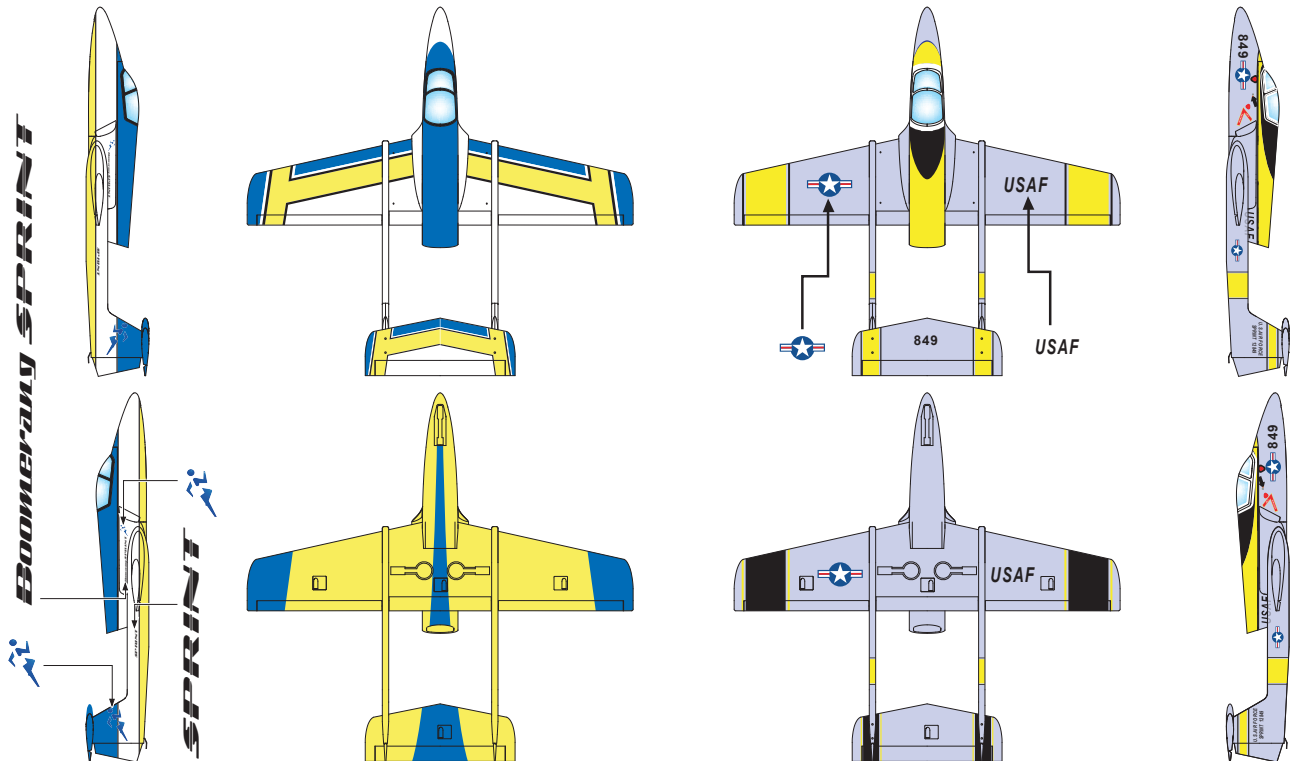

32 Control Surface Movement

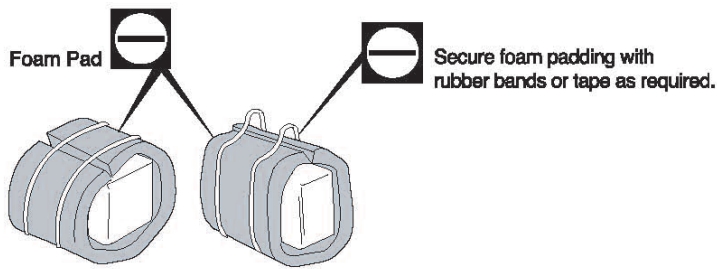

Set the travel to the values show below for the first flights. You can increase these later for aerobatics if desired.



Carefully install the receiver and battery pack to ensure that they will not shift during flight.



Shift the location of the receiver and battery pack as needed to obtain the specified CG.

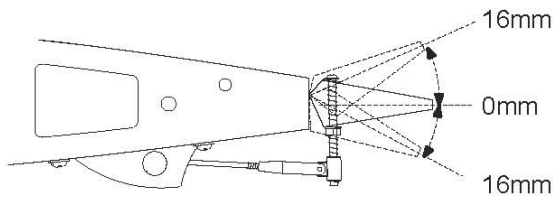

ELEVATOR

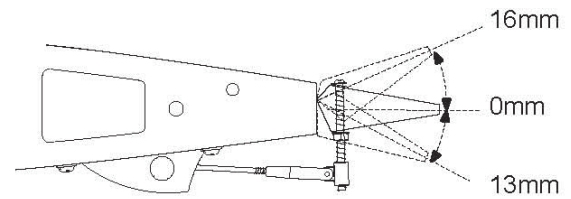

AILERON

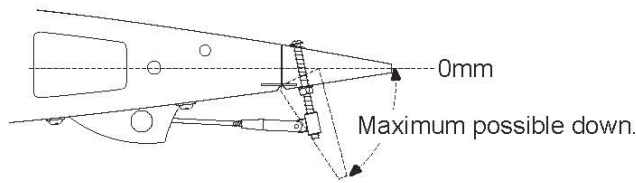

FLAP

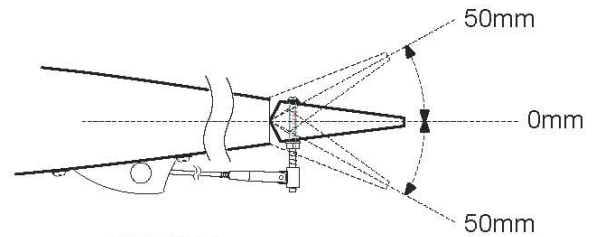

RUDDER



For first trimming flights CG should be as shown. Later you can move the CG back a small amount at a time to increase sensitivity for aerobatics.

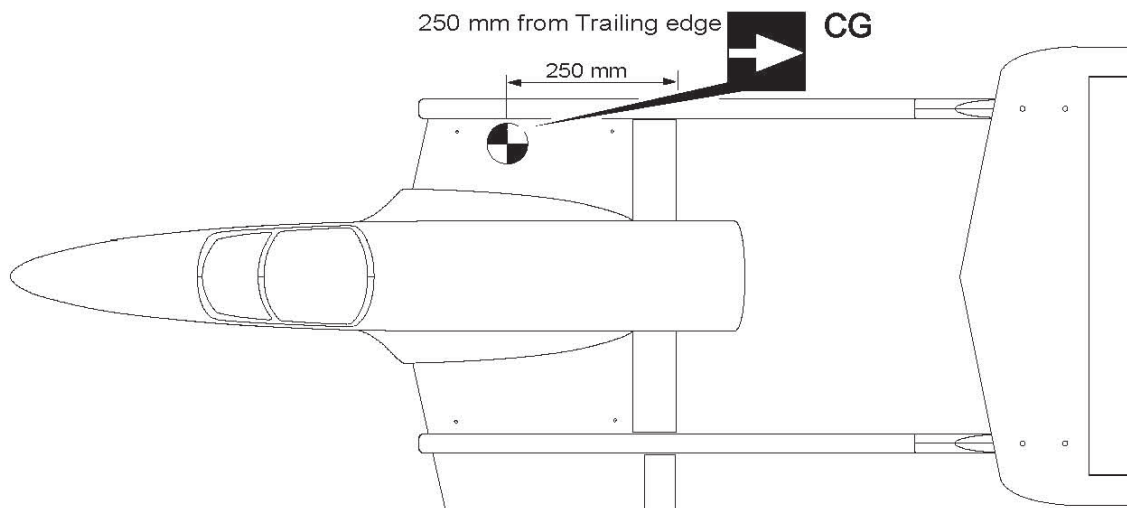

TRIMMING SET UP & FLYING NOTES

Boomerang SPRINT is not tricky or difficult to set up.

Set the Centre of Gravity no less than 10" (255 mm.) forward of the Trailing Edge for the first flights.

Start with 5/8" up and 1/2" down Aileron (16 & 13 mm.). Elevators 5/8" (16mm) up and down. Adjust later to your personal preferences.

The flap is very effective in slowing the glide speed. Set it up to drop as far as possible, to act as an airbrake. If you can add crow braking starting from half flap to full flap, to raise both ailerons about 15 to 20 degrees, the slow flight and the descent rate on the approach is remarkable, with full control at very low airspeeds using slightly open throttle allowing a high angle of attack with virtually no risk of dropping a wing.

Mix in 10% down elevator with the flap movement to prevent the nose rising as it is applied. If you have advanced mixing, this should return to zero from half flap to full down flap.

SPRINT is capable of any aerobatics you care to try, including spins both upright and inverted, snaps, tumbles, rolling circles and loops, knife edge and very slow flight.

The fuel tank custom made by Sullivan for us will give up to 15 minutes of flying time. It can, of course, be only partially filled for shorter flights if you prefer.

You should enjoy some good flying fun with the Sprint, just about the most stress free jet flying you can get! Feel free to provide your feedback and comments to us on our website:

www.Boomerang-RC-Jets.com

IMPORTANT WARNING.

READ THROUGH BEFORE ASSEMBLING OR FLYING YOUR KIT.

Just as in any full size aircraft, any R/C model aircraft can be made to fail, be it a wing folding or a fuselage breaking under too high a load. Model R/C aircraft have a maximum safe G limit. Because you are not in the plane it is difficult to judge the G during flight, and it is very easy to exceed the limits of the aircraft. This is particularly important if you install a turbine larger or more powerful than the power band specified for that particular kit. This negates any airframe warranty straight away.

All our designs are thoroughly test flown before the kit is released for sale. Turbine powered R/C model aircraft are not manufactured to withstand unlimited G forces. When flying your Boomerang Jet, be aware of the high loads which can be in excess of the airframes capability to handle. Respect the airframe as you would when flying a full size aircraft. Fit a turbine only up to the specified power.

Understand that if you perform a snap roll, wall, blender, knife edge loop or any similar manoeuvre, or pull hard on the elevator, particularly at high speed, you can over stress the airframe by up to 15 G or more. At 15 G, the 27 lbs (12.2 Kilo) model effectively weighs over 400 lbs (184 kilo), and though it may be for only a few seconds, the strain on the airframe is huge. Your model may survive those hard manoeuvres a few times, but eventually the cumulative damage will tell and airframe break up can occur.

It is common practice for any manufacturer not to replace an airframe which breaks in the air or upon landing. Manufacturers may replace airframes when they have noticed many incidences of the same failure and it is determined that there was a design fault or repeated manufacturing error. If you break an airframe, and you are the only one to do so, then it is highly unlikely to be the fault of the manufacturer. Fly safely, and avoid full throttle operation other than at low airspeeds.

R/C model jets are not toys! If misused, they can cause serious bodily harm and property damage. Fly only in open areas, and AMA (Academy of Model Aeronautics) or BMFA (British Model Flying Association) or your country's approved flying sites. Follow all manufacturer instructions included with your plane, radio, servo's, batteries and engine. Each kit is guaranteed to be free from defects in both material and workmanship at the date of purchase. Warranty does not cover any component assembled by the customer. All parts of high stress must be inspected and reinforced if necessary by a competent builder.

Some parts should be examined, and if necessary, glued again. High stress areas such as firewalls, motor mounts, wing mounts, landing gear mounts, etc., are areas of high concern. Seek help if necessary.

In no case shall Boomerang RC Jets, LLC. warranty cover any product which is not manufactured by Boomerang RC Jets, LLC. The liability to the manufacturer cannot exceed the original cost of the purchased item.

Further, Boomerang RC Jets, LLC. reserves the right to change or modify this warranty without notice. In that Boomerang RC Jets, LLC. has no control over the assembly or materials used by the builder of the model during final assembly, no liability shall be assumed nor accepted for any damage resulting from the use of the final user-assembled product. By using the user assembled product, the user accepts all resulting liability. The kits manufacturers have provided you with a top quality, thoroughly tested kit and instructions, but ultimately the quality and flying ability of your finished model depends on how you build it. Therefore, we cannot in any way guarantee the performance of your completed model, and no representations are expressed or implied as to the performance or safety of your completed model. It is the user's responsibility to inspect each component for airworthiness.