

- I** QUADRO COMANDO
- GB** CONTROL PANEL
- F** CENTRALE DE COMMANDE
- D** STEUERUNG
- E** CUADRO DE MANDOS
- P** QUADRO DE COMANDO

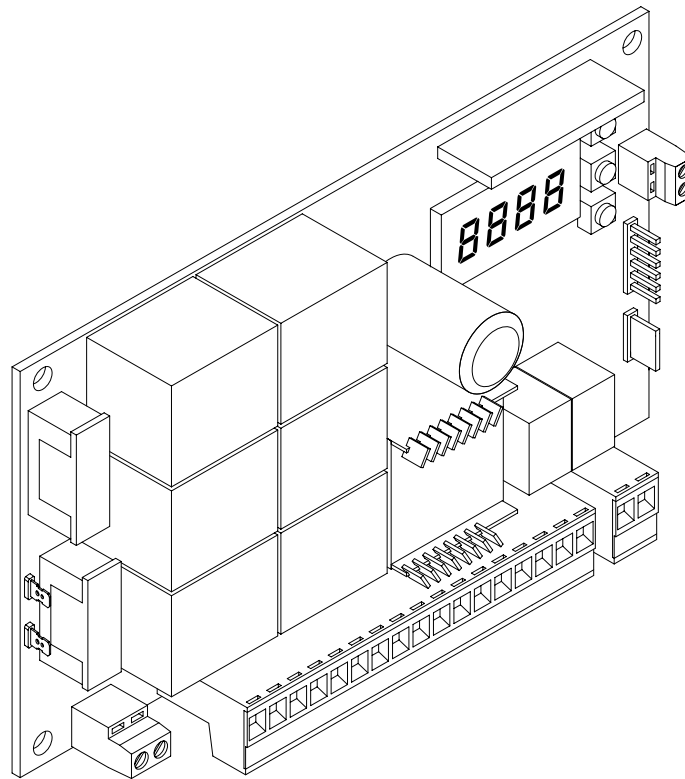

# LIBRA



**ISTRUZIONI D'USO E DI INSTALLAZIONE**  
**INSTALLATION AND USER'S MANUAL**  
**INSTRUCTIONS D'UTILISATION ET D'INSTALLATION**  
**INSTALLATIONS-UND GEBRAUCHSANLEITUNG**  
**INSTRUCCIONES DE USO Y DE INSTALACION**  
**INSTRUÇÕES DE USO E DE INSTALAÇÃO**



**AZIENDA CON SISTEMA QUALITÀ**  
**CERTIFICATO DA DNV**  
**UNI EN ISO 9001**

Via Lago di Vico, 44  
 36015 Schio (VI)  
 Tel.naz. 0445 696511  
 Tel.int. +39 0445 696533  
 Fax 0445 696522  
 Internet: [www.bft.it](http://www.bft.it)  
 E-mail: [sales@bft.it](mailto:sales@bft.it)

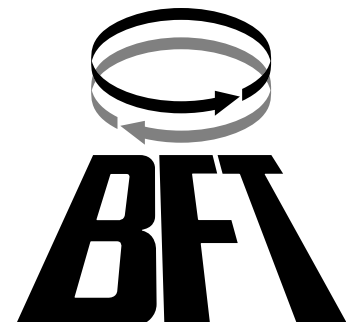

Thank you for buying this product, our company is sure that you will be more than satisfied with its performance.

This product is supplied with an "Instruction Manual" which should be read carefully as it provides important information about safety, installation, operation and maintenance.

This product complies with recognised technical standards and safety regulations. We declare that it is in conformity with the following European Directives: 89/336/EEC, 73/23/EEC, 98/37/EEC and subsequent amendments.

## 1) GENERAL SAFETY

**WARNING! An incorrect installation or improper use of the product can cause damage to persons, animals or things.**

- The "Warnings" leaflet and "Instruction booklet" supplied with this product should be read carefully as they provide important information about safety, installation, use and maintenance.
- Scrap packing materials (plastic, cardboard, polystyrene etc) according to the provisions set out by current standards. Keep nylon or polystyrene bags out of children's reach.
- Keep the instructions together with the technical brochure for future reference.
- This product was exclusively designed and manufactured for the use specified in the present documentation. Any other use not specified in this documentation could damage the product and be dangerous.
- The Company declines all responsibility for any consequences resulting from improper use of the product, or use which is different from that expected and specified in the present documentation.
- Do not install the product in explosive atmosphere.
- The construction components of this product must comply with the following European Directives: 89/336/CEE, 73/23/EEC, 98/37/EEC and subsequent amendments. As for all non-EEC countries, the above-mentioned standards as well as the current national standards should be respected in order to achieve a good safety level.
- The Company declines all responsibility for any consequences resulting from failure to observe Good Technical Practice when constructing closing structures (door, gates etc.), as well as from any deformation which might occur during use.
- The installation must comply with the provisions set out by the following European Directives: 89/336/CEE, 73/23/EEC, 98/37/EEC and subsequent amendments.
- Disconnect the electrical power supply before carrying out any work on the installation. Also disconnect any buffer batteries, if fitted.
- Fit an omnipolar or magnetothermal switch on the mains power supply, having a contact opening distance equal to or greater than 3mm.
- Check that a differential switch with a 0.03A threshold is fitted just before the power supply mains.
- Check that earthing is carried out correctly: connect all metal parts for closure (doors, gates etc.) and all system components provided with an earth terminal.
- Fit all the safety devices (photocells, electric edges etc.) which are needed to protect the area from any danger caused by squashing, conveying and shearing.
- Position at least one luminous signal indication device (blinker) where it can be easily seen, and fix a Warning sign to the structure.
- The Company declines all responsibility with respect to the automation safety and correct operation when other manufacturers' components are used.
- Only use original parts for any maintenance or repair operation.
- Do not modify the automation components, unless explicitly authorised by the company.
- Instruct the product user about the control systems provided and the manual opening operation in case of emergency.
- Do not allow persons or children to remain in the automation operation area.
- Keep radio control or other control devices out of children's reach, in order to avoid unintentional automation activation.
- The user must avoid any attempt to carry out work or repair on the automation system, and always request the assistance of qualified personnel.
- Anything which is not expressly provided for in the present instructions, is not allowed.

## 2) GENERAL OUTLINE

The LIBRA control panel is supplied by the manufacturer with standard setting. Any alteration must be set by means of the incorporated display programmer or by means of UNIPRO. The Control unit completely supports the EELINK protocol.

Its main characteristics are:

- Control of two low-voltage motors up to 40W power
- Electronic torque setting with obstacle detection

- Limit-switch control inputs
- Separate inputs for safety devices
- Incorporated radio receiver

The board is provided with a terminal board which can be pulled out for easier maintenance or replacement. The board is supplied with a series of pre-wired jumpers to facilitate the installer's work.

The jumpers relate to the following terminals: 15-17 and 15-18. If the above-mentioned terminals are in use, remove their respective jumpers.

## 3) TECHNICAL DATA

Power supply: .....	230Va.c. ±10% 50Hz*
Mains/low voltage insulation: .....	> 2MΩm 500Vdc
Dielectric strength:.....	mains/low voltage 3750Vac per 1 minute
Motor output current: .....	3.5A+3.5A max
Motor relay commutation current: .....	10A
Maximum motor power: .....	40W (24Vd.c.)
Supply to accessories: .....	24Va.c. (180mA max absorption)
	24Va.c. V safe (180mA max absorption)
Gate-open warning light: .....	N.O. contact (24Va.c./1A max)
Blinker: .....	24Va.c. 25W max
Dimensions: .....	see figure 1
Fuses: .....	see figure 2

(\* other voltages available on request)

## BATTERY KIT BT BAT (Fig.6)

Charging voltage: .....	27.2Vdc
Charging current: .....	130mA
Outside temperature when values were measured: .....	25°C
Battery capacity: .....	2x (12V 1.2Ah)
Flat battery protection threshold: .....	20.4Vd.c.
Battery charging time: .....	12/14 hrs

## 4) TERMINAL BOARD CONNECTIONS (Fig.3)

**WARNING** – During the wiring and installation operations, refer to the current standards as well as principles of good technical practice.

Wires powered at different voltages must be physically separated, or suitably insulated with at least 1 mm extra insulation. The wires must be clamped by an extra fastener near the terminals, for example by bands. All the connection cables must be kept at an adequate distance from the dissipator.

**WARNING! For connection to the mains, use a multipolar cable with a minimum of 3x1.5mm<sup>2</sup> cross section and complying with the previously mentioned regulations. For example, if the cable is outside (in the open), it has to be at least equal to H07RN-F, but if it is on the inside (or outside but placed in a plastic cable channel) it has to be or at least equal to H05VV-F with section 3x1.5mm<sup>2</sup>.**

### JP1

1-2 Single-phase mains power supply 230Va.c. ±10% (1=L) (2=N)

### JP9

3-4-5 Connection to motor 2:  
3 motor + (red)  
4 motor - (black),  
5 limit-switch control (white)

### 6-7-8

Connection to motor 1:  
6 motor + (red)  
7 motor - (black)  
8 limit-switch control (white)  
Connection to blinker (24Va.c. 20W max)

### 9-10

### JP8

11-12 Output 24Va.c. 180mA max - supply to photocells or other devices

13-14 Output 24Va.c. V safe 180mA max - supply to photocell transmitters with checking function (Fig.3a).

15-16 START pushbutton (N.O.).

15-17 STOP pushbutton (N.C.). If not used, leave the bridge 15-17 connected.

15-18 Photocell input (N.C.). If not used, leave the bridge 15-18 connected.

15-19 Fault input (N.O.). Input for photocells provided with checking N.O. contact (Fig. 3a).

15-20 Pedestrian pushbutton input (N.O.). Activation is carried out by motor 2; if the opening cycle has started (not from pedestrian function), the pedestrian command has no effect.

## JP7

21-22 Output for gate-open warning light output (N.O. contact (24Va.c./1A max)) or alternatively 2nd radio channel (see paragraph 5 on "Configuration")

23-24 Antenna input for radio-receiver plug-in board (23 braid–24 signal).

## 5) PROGRAMMING

The control panel provided with a microprocessor is supplied with function parameters preset by the manufacturer, suitable for standard installations. The predefined parameters can be altered by means of either the incorporated display programmer or UNIPRO.

In the case where programming is carried out by means of UNIPRO, carefully read the instructions relating to UNIPRO, and proceed in the following way.

Connect the UNIPRO programmer to the control unit through the UNIFLAT and UNIDA accessories (See fig. 4). The Libra control unit does not supply the UNIPRO programmer with power, and therefore requires an appropriate supply unit.

Enter the "CONTROL UNITS" menu, and the "PARAMETERS" submenu, then scroll the display screenfuls using the up/down arrows to set the numerical values of the parameters listed below.

For the function logics, refer to the "LOGIC" submenu.

In the case where programming is carried out by means of the incorporated programmer, refer to Fig. A and B and to the paragraph on "Configuration".

## 6) CONFIGURATION

The display programmer is used to set all the LIBRA control panel functions. The programmer is provided with three pushbuttons for menu scrolling and function parameter configuration:

+ menu scrolling/value increment key

- menu scrolling/value reduction key

OK Enter (confirm) key

The simultaneous pressure of the + and - keys is used to exit the active menu and move to the preceding menu.

The modifications made are only set if the OK key is subsequently pressed. When the OK key is pressed for the first time, the programming mode is entered.

The following pieces of information appear on the display at first:

- Control unit software version
- Number of total manoeuvres carried out (the value is expressed in thousands, therefore the display constantly shows 0000 during the first thousand manoeuvres)
- Number of manoeuvres carried out since the latest maintenance operation (the value is expressed in thousands, therefore the display constantly shows 0000 during the first thousand manoeuvres)
- Number of memorised radio control devices.

When the OK key is pressed during the initial presentation phase, the first menu can be accessed directly.

Here follows a list of the main menus and the respective submenus available. The predefined parameter is shown between square brackets [ 0 ].

The writing appearing on the display is indicated between round brackets. Refer to Figures A and B for the configuration procedure.

## 6.1) PARAMETER MENU (PAR-PR)

## - Automatic Closing Time (tCR) [ 10s ]

Set the numerical value of the automatic closing time from 3 to 60 seconds.

## - Motor 1 torque (fot i torQUE) [ 50% ]

Set the numerical value of the motor 1 torque between 1% and 99%.

## - Motor 2 torque (fot 2 torQUE) [ 50% ]

Set the numerical value of the motor 2 torque between 1% and 99%.

**NOTE: In case of obstacle detection, the Ampere-stop function halts the leaf movement, reverses its motion for 1 sec. and then halts in the STOP status.**



**WARNING: Check that the impact force value measured at the points established by the EN 12445 standard is lower than that specified in the EN 12453 standard.**



**Incorrect torque setting can cause injuries to persons or animals, or damage to things.**

## - Opening delay time (oPEN dELAY tIME) [ 1s ]

Set the opening delay time for motor 1 relative to motor 2, between 1 and 5 seconds.

## - Closing delay time (cLS dELAY tIME) [ 1s ]

Set the closing delay time for motor 2 relative to motor 1, between 1 and 5 seconds.

## - Zone (zonE) [ 0 ]

Set the zone number between a minimum value of 0 and a maximum value of 127. See paragraph 7 on "Serial connection".

## 6.2) LOGIC MENU (LoGic)

## - TCA (tCR) [ OFF ]

ON Activates automatic closing

OFF Excludes automatic closing

## - 3 Steps (3 StEP) [ OFF ]

ON Enables 3-step logic. A Start impulse has the following effects:

door closed: ..... opens

on opening: ..... stops and enters TCA (if configured)

door open: ..... closes

on closing: ..... stops and reopens

OFF Enables 4-step logic. A Start impulse has the following effects:

door closed: ..... opens

on opening: ..... stops and enters TCA (if configured)

door open: ..... closes

on closing: ..... stops and does not enter TCA (stop)

after stopping: ..... opens

## - Impulse lock (iBL oPEN) [ OFF ]

ON The Start impulse has no effect during the opening phase.

OFF The Start impulse becomes effective during the opening or closing phase.

## - Rapid closing (FRSt cLS) [ OFF ]

ON Closes the gate after photocell disengagement, before waiting for the end of the TCA set.

OFF Command not entered.

## - Photocells on opening (Photo. oPEN) [ OFF ]

ON: In case of obscuring, this excludes photocell operation on opening. During the closing phase, it immediately reverses the motion.

OFF: In case of obscuring, the photocells are active both on opening and on closing. When a photocell is obscured on closing, it reverses the motion only after the photocell is disengaged.

## - Photocell test (tEst Phot) [ OFF ]

ON Activates photocell check

OFF Deactivates photocell check

If this setting is not activated (OFF), it inhibits the photocell checking function, allowing connection of devices not provided with additional checking contact.

## - Gate-open or 2nd radio channel warning light (5 tOnRL InG oUtEP) [ OFF ]

ON The output between terminals 21 and 22 is configured as Gate-open warning light, in this case the 2nd radio channel controls pedestrian opening.

OFF The output between terminals 21 and 22 is configured as 2nd radio channel.

## - Motors in operation (iMot on) [ OFF ]

ON Only motor 2 is in operation (terminals 3, 4 and 5).

With this configuration, the pedestrian input is disabled.

OFF Both motors are in operation.

## - Lock hold (bLoCH PER-5 tSt) [ OFF ] (Fig. 5)

ON To be used when the mechanical closing backstop is fitted.

This function activates leaf pressure on the mechanical backstop, without this being considered as an obstacle by the Ampere-stop sensor.

Therefore the rod continues its travel for another 0.5 sec. after detecting the closing limit switch or upon reaching the mechanical backstop. So by activating the closing limit switches slightly earlier, the leaves will come to a perfect halt against the backstop. (Fig. 5a)

OFF To be used when no mechanical closing backstop is fitted.

Movement is exclusively halted by activation of the closing limit switches; in this case proceed to carrying out precise setting of the closing limit-switch activation. (Fig. 5b)

## - Master/Slave (MRStEr) [ OFF ]

ON The control panel is set as Master in a centralised connection (see Paragraph 7).

OFF The control panel is set as Slave in a centralised connection (see Paragraph 7).

## - Loop (LooP) [ OFF ]

ON In the case of a closed loop centralised connection (Fig.7), set the control unit to ON.

OFF In the case of an open centralised connection (Fig.7), set the control unit to OFF.

## 6.3) RADIO MENU (rRd io)

## - Add

Allows you to add one key of a radio control device to the receiver memory; after storage it displays a message showing the receiver

number in the memory location (from 01 to 64).

**Add Start button** (*Add Start*)

associates the required key to Start command

**Add 2ch button** (*Add 2ch*)

associates the required key to 2nd radio channel

- **Read** (*Read*)

Checks one key of a receiver; if stored it displays a message showing the receiver number in the memory location (from 01 to 64), and the key number (T1, T2, T3 or T4).

- **Delete** (*ERASE 1*)

Removes one single key of a transmitter from the receiver memory; after deletion it displays a message showing the receiver number in the memory location (from 01 to 64).

- **Eliminate list** (*ERASE 54*)

**WARNING!** Completely removes all memorised radio control devices from the receiver memory.

#### 6.4) LANGUAGE MENU (*LANGUAGE*)

Allows you to set the language on the display programmer.

- **ITALIAN** (*ItA*)

- **FRENCH** (*FRF*)

- **GERMAN** (*DEU*)

- **ENGLISH** (*ENG*)

- **SPANISH** (*ESP*)

#### 6.5) DEFAULT MENU (*DEFAULT*)

Restores the preset default values on the control unit. After restoring, a new autoselection operation must be carried out.

#### 6.6) DIAGNOSTICS AND MONITORING

The display on the **LIBRA** panel shows some useful information, both during normal operation and in the case of malfunctions.

**Diagnostics:**

In the case of malfunctions, the display shows a message indicating which device needs to be checked:

STRT= START input activation

STOP= STOP input activation

PHOT= PHOT input activation

FLT = FAULT input activation for checked photocells

In the case where an obstacle is found, the **LIBRA** panel stops the door and activates a reverse manoeuvre; at the same time the display shows the "AMP" message.

**Monitoring:**

During the opening and closing phases, the display shows four digits separated by a dot, for example 35.40. The digits are constantly updated during the manoeuvre, and represent the maximum torque reached by motor 1 (35) and motor 2 (40).

These values allow the torque setting to be corrected.

If the maximum torque value reached during the manoeuvre gets sensibly close to the value set in the parameter menu, malfunctions may occur in the future following wear or slight door deformation.

It is therefore advisable to check the maximum torque reached during some of the manoeuvres carried out in the course of installation, and if necessary set a value about 15-20 percent points higher in the parameter menu.

#### 6.7) AUTOSET MENU (*AutoSet*)

Allows you to automatically set the Motor torque.

**WARNING!!** The autoselection operation is only to be carried out after checking the exact leaf (opening/closing) movement, and correct limit-switch activation.

As soon as the OK pushbutton is pressed, the "... .." message is displayed, and the control unit executes an opening manoeuvre followed by a closing manoeuvre, during which the minimum torque value needed for leaf movement is automatically set.

During this phase, it is important to avoid obscuring the photocells, as well as using the START, STOP or PED commands and the display.

After this, if autoselection has been successfully completed, the control unit displays the "OK" message and, after pressing any key, returns to the Autoselection menu.

If, on the other hand, the control unit displays the "KO" message, it means that the autoselection procedure has not been successfully completed; it is thus necessary to check the wear condition of the gate and the regular movement of the leaves before proceeding to a new autoselection operation.

**WARNING!** During the autoselection phase, the obstacle detection function is not active, therefore the installer must control the automation movement and prevent persons and things from approaching or standing within the automation working range.

In the case where buffer batteries are used, autoselection must be carried out with the control panel supplied by mains power voltage.



**WARNING: Check that the impact force value measured at the points established by the EN 12445 standard is lower than that specified in the EN 12453 standard.**



**Incorrect torque setting can cause injuries to persons or animals, or damage to things.**

#### 6.8) Statistics

Having connected the UNIPRO programmer to the control unit, enter the CONTROL UNIT / STATISTICS menu and scroll the screenful showing the statistical parameters:

- Board microprocessor software version.
- Number of cycles carried out. If motors are replaced, count the number of manoeuvres carried out up to that time.
- Number of cycles carried out from the latest maintenance operation. It is automatically set to zero after each self-diagnosis or parameter writing.
- Date of latest maintenance operation. To be updated manually from the appropriate menu "Update maintenance date".
- Installation description. 16 characters can be entered for installation identification.

#### 7) SERIAL CONNECTION USING SCS BOARD (Fig.7)

The **LIBRA** control panel allows several automation units (SCS) to be connected in a centralised way by means of appropriate serial inputs and outputs. This makes it possible to use one single command to open and close all the automation units connected.

Following the diagram in Fig.7, proceed to connecting all the **LIBRA** control panels, exclusively using a telephone-type line.

Should a telephone cable with more than one pair be needed, it is indispensable to use wires from the same pair.

The length of the telephone cable between one appliance and the next must not exceed 250 m.

At this point, each of the **LIBRA** control panels must be appropriately configured, by setting a MASTER unit first of all, which will have control over all the others, to be necessarily set as SLAVE (see logic menu).

Also set the Zone number (see parameter menu) between 0 and 127.

**The zone number allows you to create groups of automation units, each one answering to the Zone Master unit.** Each zone can only be assigned one Master unit, the Master unit in zone 0 also controls the Slave units in the other zones.

Loop closing of the serial connection (indicated by a dotted line in Fig.7) is only needed if you require to check the no. of the connected devices by means of UNIPRO.

#### 8) SCRAPPING

**Warning: This operation should only be carried out by qualified personnel.** Materials must be disposed of in conformity with the current regulations. In case of scrapping, the automation devices do not entail any particular risks or danger. In case of materials to be recycled, these should be sorted out by type (electrical components, copper, aluminium, plastic etc.).

#### 9) DISMANTLING

**Warning: This operation should only be carried out by qualified personnel.** When the control unit is disassembled to be reassembled on another site, proceed as follows:

- Disconnect the power supply and the entire electrical installation.
- In the case where some of the components cannot be removed or are damaged, they must be replaced.

**The descriptions and illustrations contained in the present manual are not binding. The Company reserves the right to make any alterations deemed appropriate for the technical, manufacturing and commercial improvement of the product, while leaving the essential product features unchanged, at any time and without undertaking to update the present publication.**

Fig. A

DB11323\_06

**ACCESS TO MENUS**

Press the OK key  
OK

bFt Control unit software version  
L iBrA ID No. total manoeuvres (in thousands)  
0000 No. manoeuvres since latest maintenance (in thousands)  
00 No. radio control devices memorised

**LEGENDA**

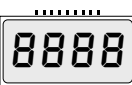

+ Simultaneously press the + and - keys. Simultaneous pressure of the + and - keys allows you to exit the active menu and return to the preceding menu; if this takes place at the main menu level, programming is exited and the display switched off. The modifications made are only confirmed if the OK key is subsequently pressed.  
 - Simultaneously press the - and + keys.  
 OK Press OK key (Enter/confirm)

Preset value  
 +/ON -/OFF Parameter increment/reduction or ON/OFF commutation  
 Press OK key (Enter/confirm)  
 - Menu scrolling (+ = preceding - = following)

Message: Programming in progress  
 Message: KO! (value or function error)  
 Message: "Wait" (enter value or function)

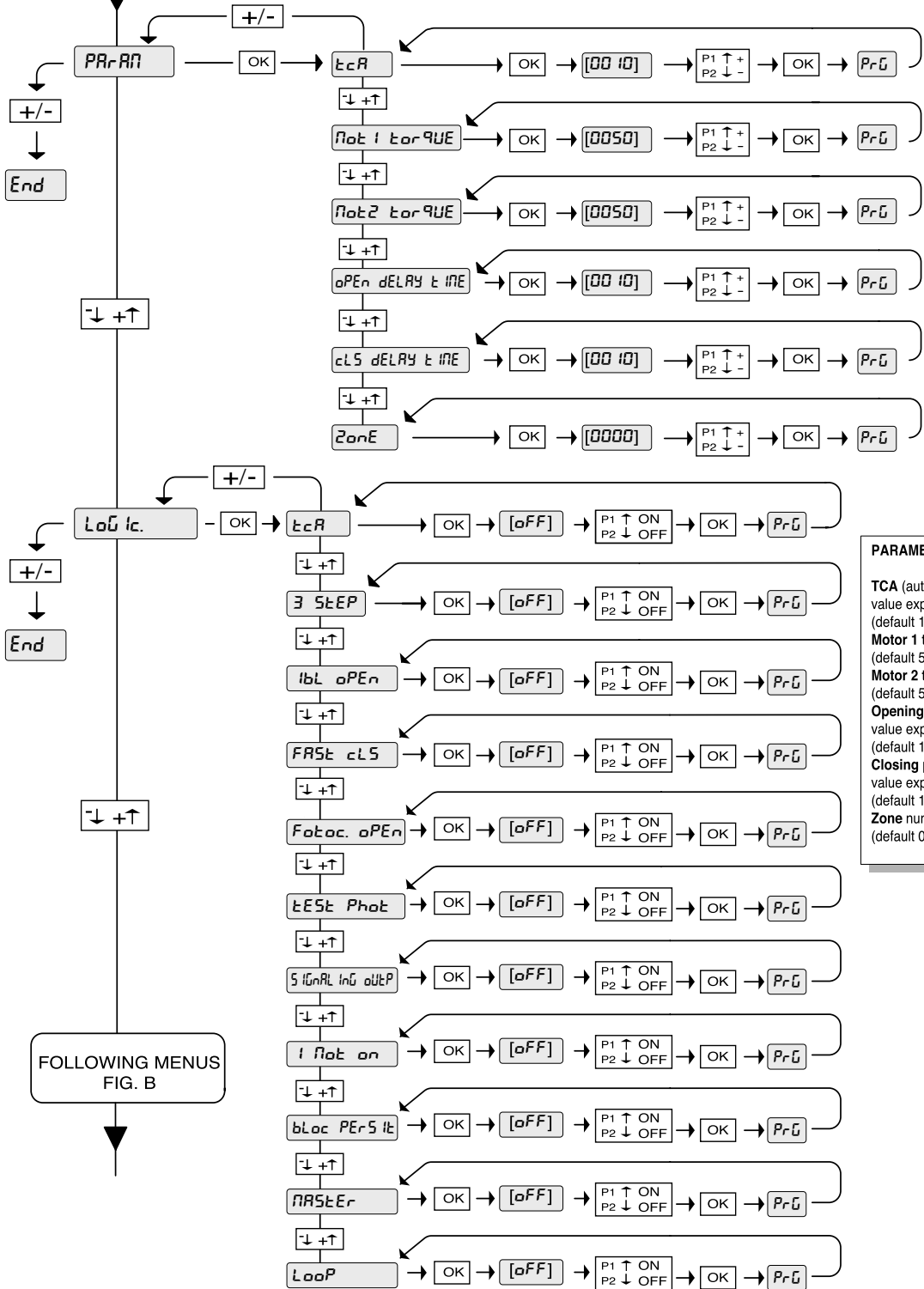

**PARAMETER MENU**

**TCA** (automatic closing time)  
value expressed in seconds  
(default 10=10s, min 3=3s, max 60=60s)

**Motor 1 torque** value expressed in %  
(default 50%, min 1%, max 99%)

**Motor 2 torque** value expressed in %  
(default 50%, min 1%, max 99%)

**Opening phase-difference Time**  
value expressed in tenths of a second  
(default 10=1s, min 10=1s, max 50=5s)

**Closing phase-difference Time**  
value expressed in tenths of a second  
(default 10=1s, min 10=1s, max 50=5s)

**Zone** numerical value  
(default 0, min 0, max 127)

FOLLOWING MENUS  
FIG. B

Fig. B

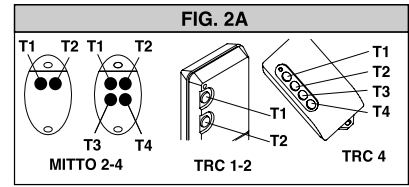
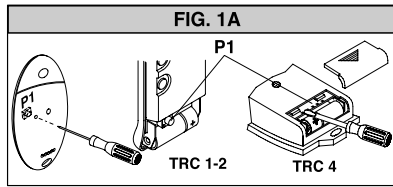

PRECEDING MENUS  
FIG. A

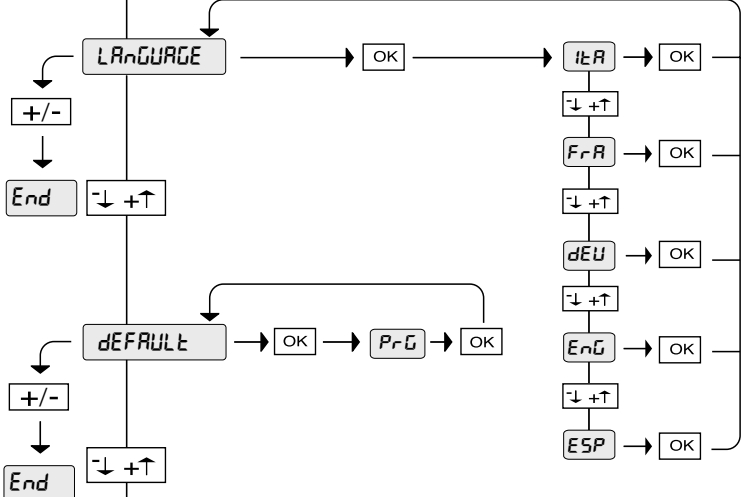
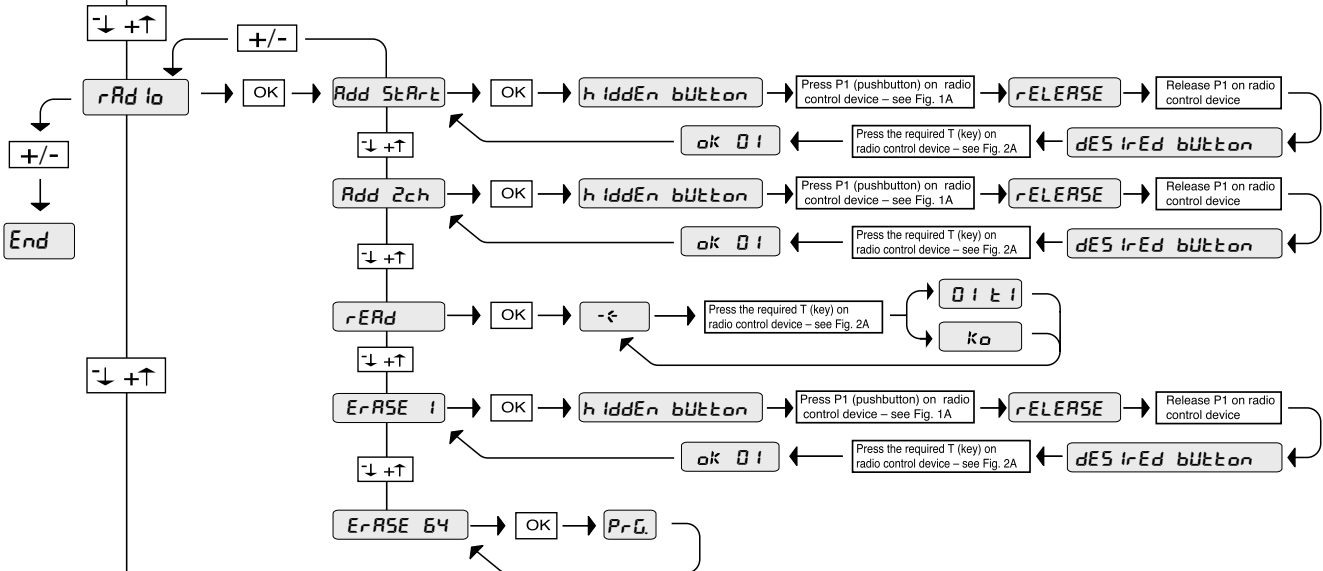

**RADIO MENU**

**ADD** - Allows you to add one key of a radio control device to the receiver memory; after storage it displays a message showing the receiver number in the memory location (from 01 to 64).

**Add Start button** – associates the required key to Start command

**Add 2ch button** – associates the required key to 2nd radio channel

**READ** - Checks one key on a receiver, if stored it displays a message showing the receiver number in the memory location (from 01 to 64), and the key number (T1, T2, T3 or T4).

**ERASE 1** - Removes one single key of a transmitter from the receiver memory; after deletion it displays a message showing the receiver number in the memory location (from 01 to 64).

**ERASE 64**  
WARNING! Completely removes all memorised radio control devices from the receiver memory.

**AUTOSET MENU**

It automatically sets the motor torque.

**WARNING!** During the autaset phase, the obstacle detection function is not active, therefore the installer must control the automation movement and prevent persons and things from approaching or standing within the automation working range.

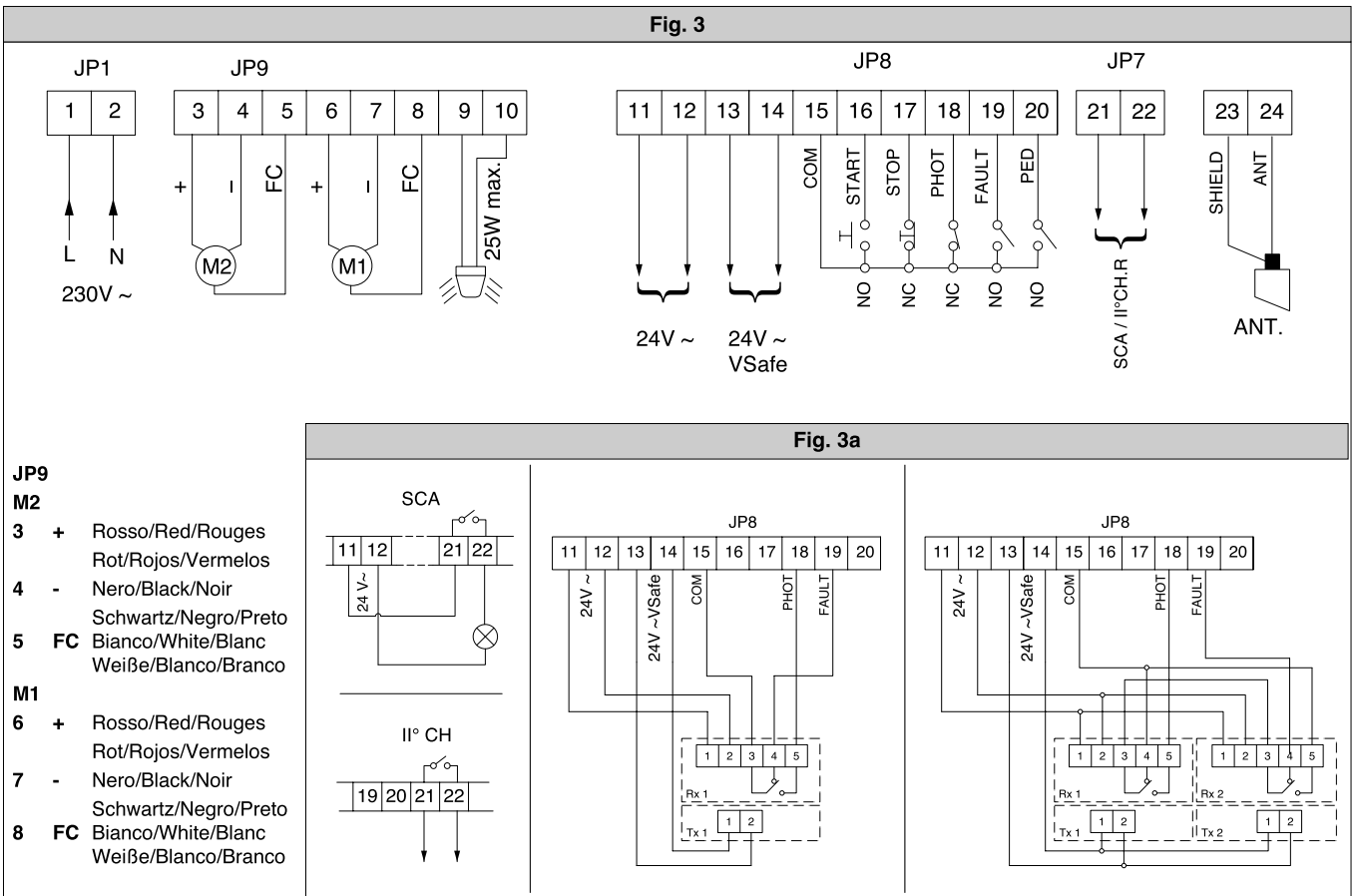
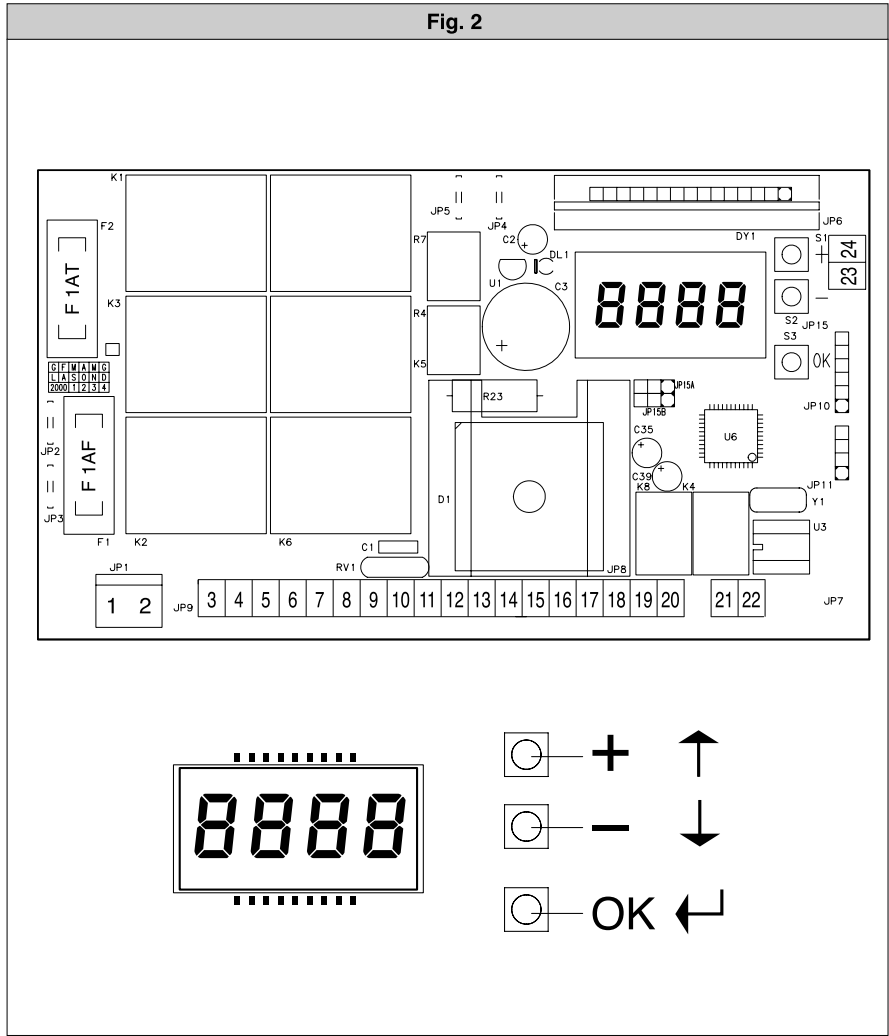
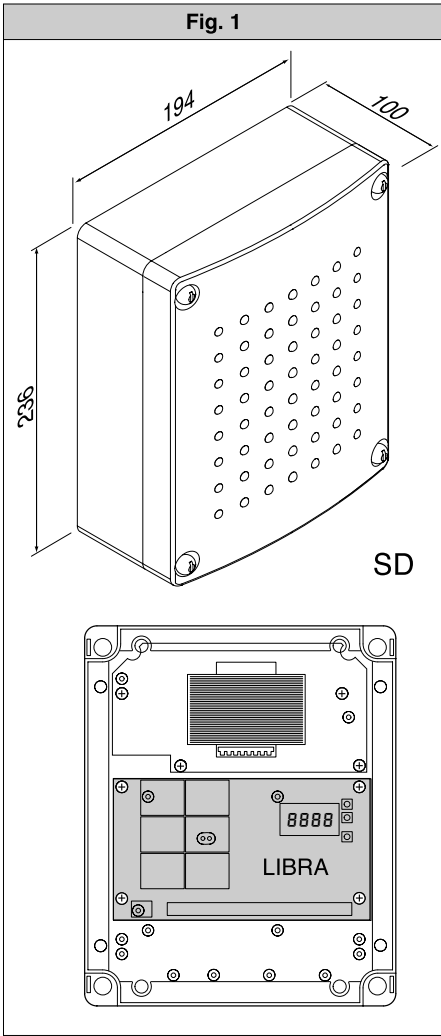

Fig. 4

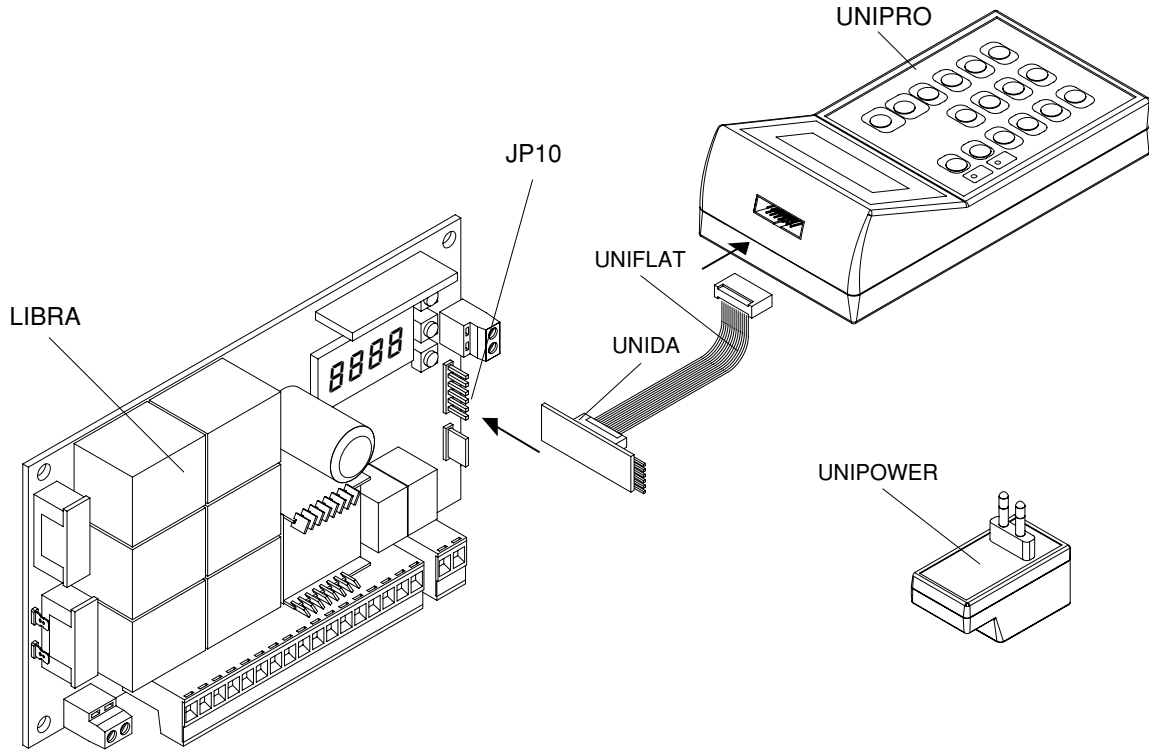

Fig. 5

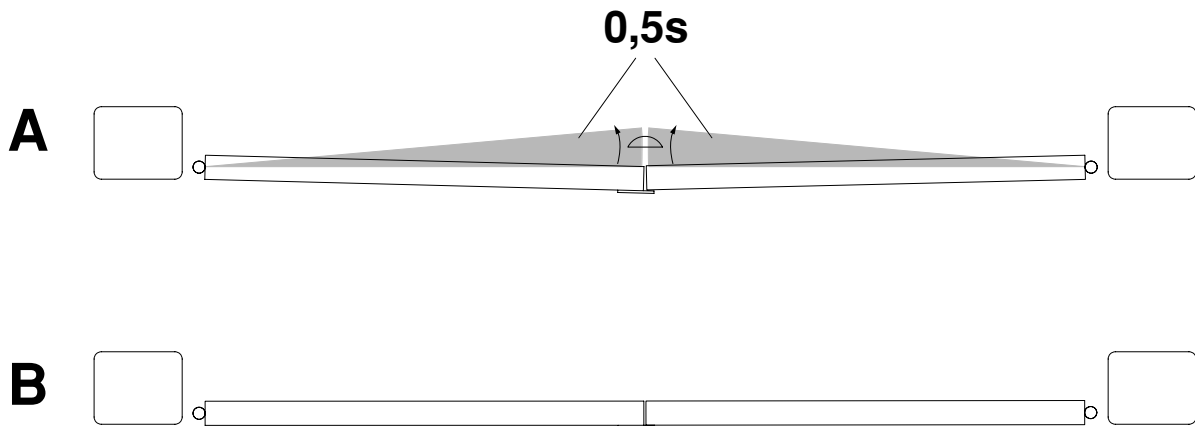
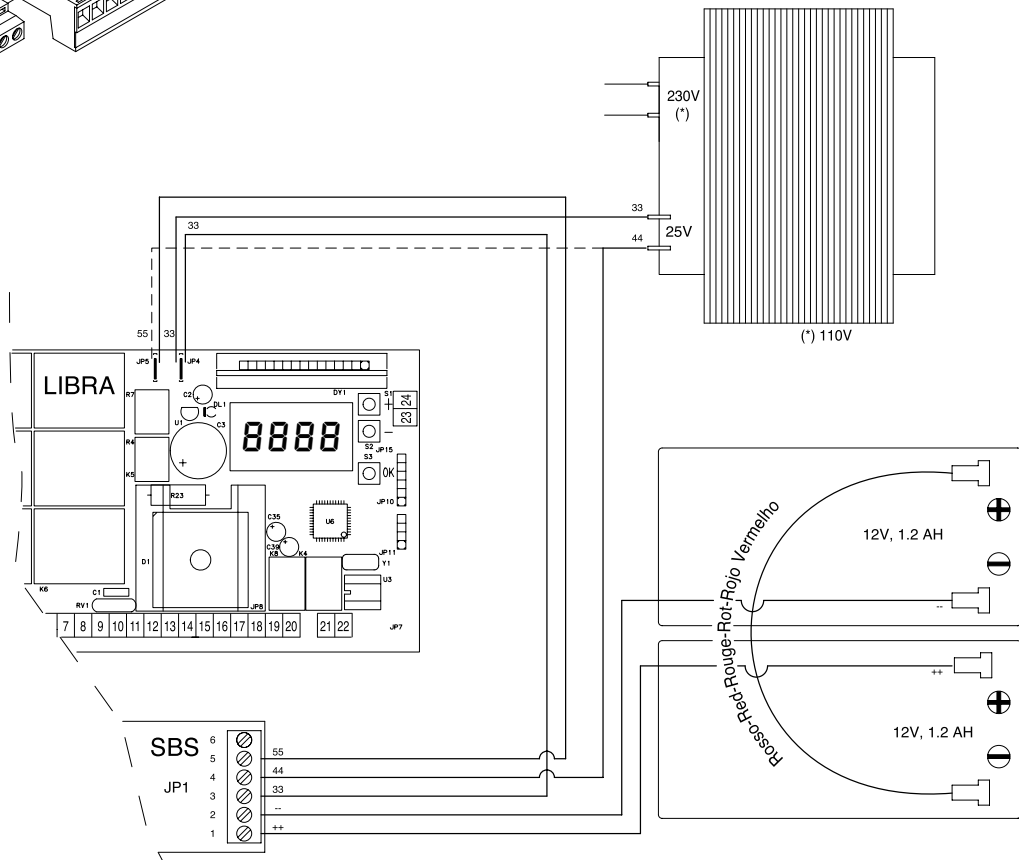
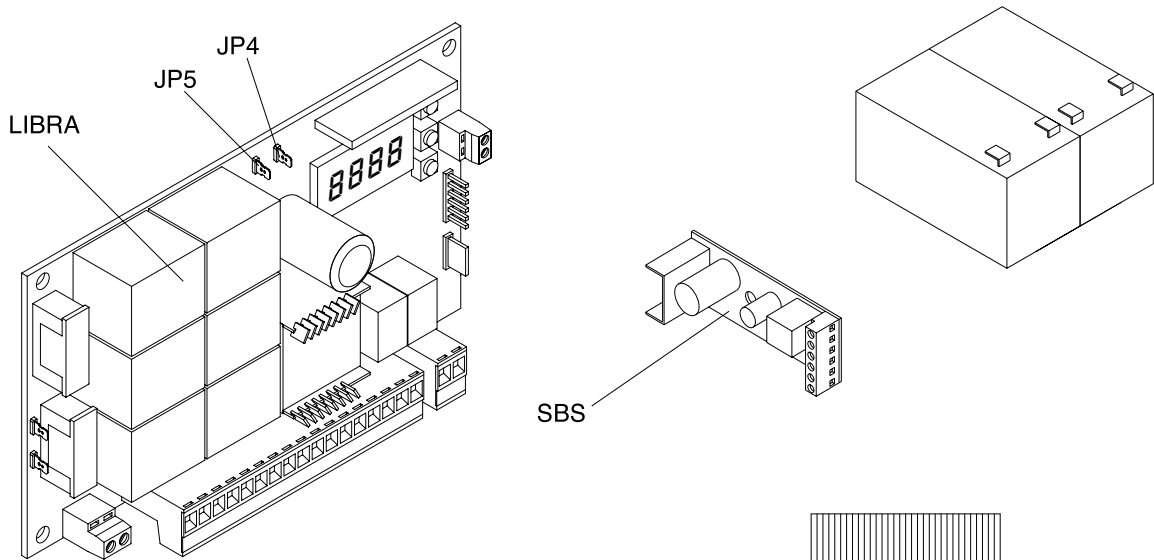



Fig. 6

DB11323\_06



JP8

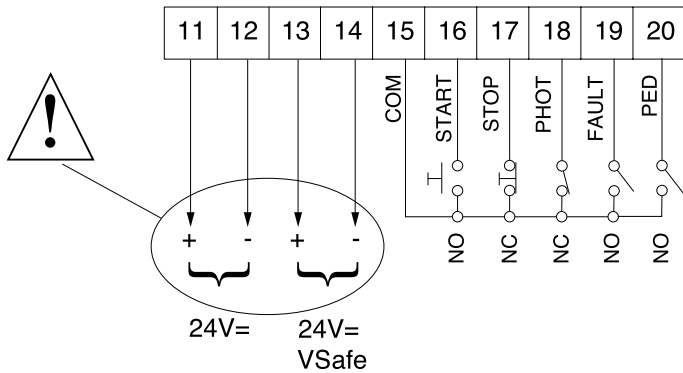

Fig. 7

