

User's Manual

TRP80USE THERMAL RECEIPT PRINTER

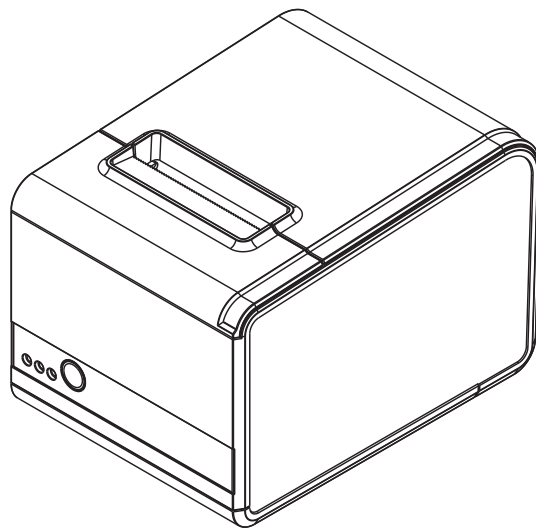

Proficient in Commercial POS Receipt Printers

1. Safety Notice:

- * Don't touch the printer head with anything.
- * Don't touch the cutter blade.
- * Don't bend the power cord excessively or place any heavy objects onto it.
- * Don't use the printer when it is out of order. This can cause a fire or and electrocution.
- * When connecting or disconnecting the plug, always hold the plug but not the cord.
- * Keep the desiccant out of children's reach.
- * Use only approved accessories and do not try to disassemble, repair or remodel it by yourself.
- * Install the printer on the stable surface. Choose firm, level surface where avoid vibration.
- * Don't let water or other foreign objects into the printer.
- * Don't connect a telephone line into the peripheral drive connector.
- * We recommend that you unplug the printer from the power outlet if no use it for a long period .

2. Applications:

- * POS system Receipts
- * EFT POS system Receipts
- * Gym, post, hospital, civil aviation system Receipts
- * Inquiry, Service system Receipts
- * Instrument test Receipts
- * Tax, Tab Receipts

3. Unpacking

After unpacking the unit, check that all the necessary accessories are included in the package.

User's Manual	1 PCS
Printer	1 PCS
Serial Cable	1 PCS
Power Adapter (include power cord)	1 SET

4. Features

- 250mm/s high speed printing
- 3-in-1 interfaces and inverted design of mainboard, ideal for kitchen
- Separated cutter and print head on mechanism
- Compatible with ESC/POS command set
- Built-in Web page to set up printer directly
- Support Ethernet printing status monitor
- Auto-recovery printing after internet disconnecton
- Faster connection by 10M Ethernet port to avoid receipt misprinting
- Support character sets GB18030 and various international languages
- Support printer identification, software binding and high speed driver mode
- Support different density bitmap and download graphics printing
- Support character enlargement, bold, underline, line spacing and character spacing
- Water-proof, Oil-proof, Dust-proof

5. Specifications

Model	TRP80USE
Printing speed	250mm/sec
Printing width	79.5±0.5mm
Dot pitch	576dots / line&512dots / line
Character size	ANK Character, Font A: 12×24dots, Font B: 9×17dots, Chinese Character: 24×24dots
Print command	Compatible with ESC/POS
Interface	USB+Serial+Ethernet
Auto cutter	Partial
Reliability print	150KM
Barcode mode	UPC-A/UPC-E/JAN13(EAN13)/ JAN8(EAN8)/CODE39/ITF/CODABAR/ CODE93/CODE128
Paper thickness	0.06~0.08mm
Power adapter	Input: AC110V~220V, 50~60HZ Output: DC 24V/1.5A
Powersupply	DC 24V/1.5A
Cash drawer	DC 24V/1A
Work temperature	Temperature: 0~45°C, Dampness: 10~80%
Storage temperature	Temperature: -10~60°C, Dampness: 10~90%
Dimensions	200*152*138mm (WxDxH)

6. Printer Connection

- Plug the DC cord connector into the printer's power connector.
- Plug the data cable connector into the printer's interface connector.
- Plug the drawer cable into the drawer kick-out connector on the back of the printer next to the interface connector.

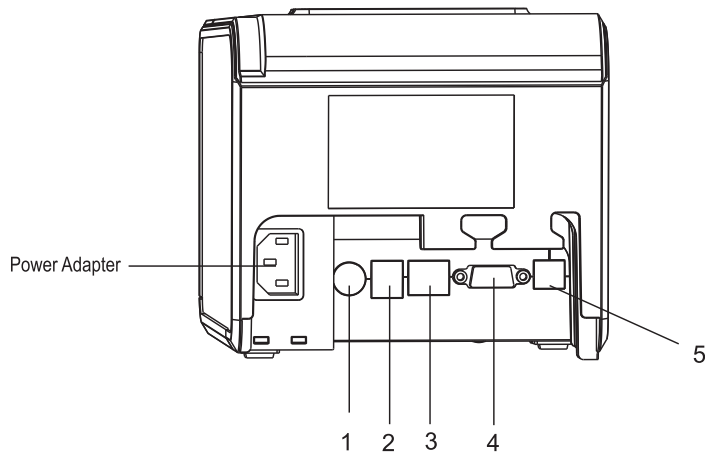

1 - Power Cord 2 - Cash drawer 3 - Ethernet 4 - Serial port 5 - USB

7. Installing the roll paper

- Open the printer cover.
- Install the roller in the roll paper, and put them into the printer.
- Pull out some paper outside the printer.
- Close the top cover. Press the printer cover to avoid error position of roll paper.

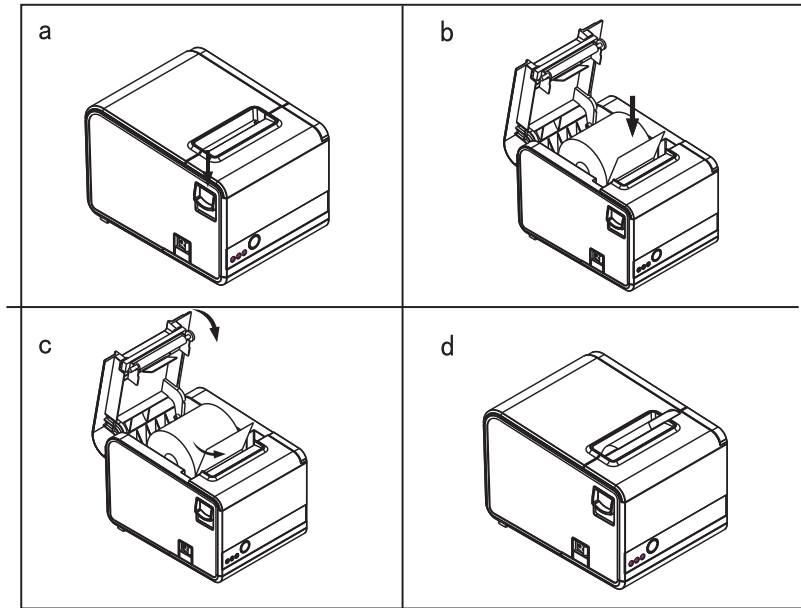

8. Setting the Printing Mode (DIP switches)

The DIP switches are used to set the printer to perform various functions, such as cutter mode, character set, speed, beeper, print density and etc.

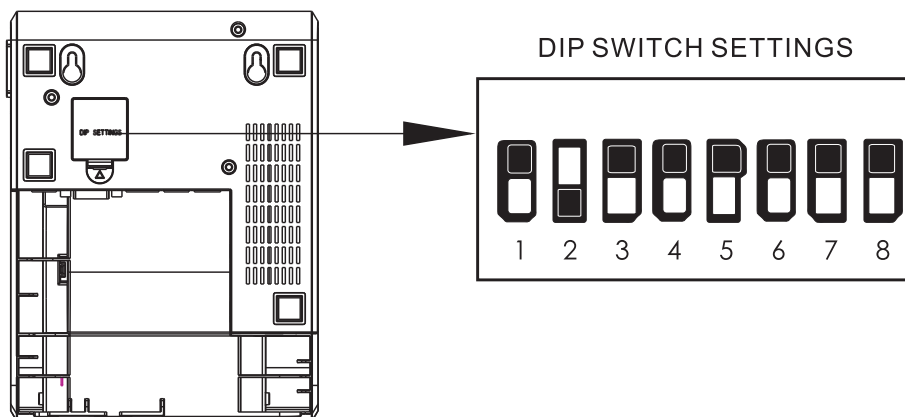

9. Buttons and Indicators

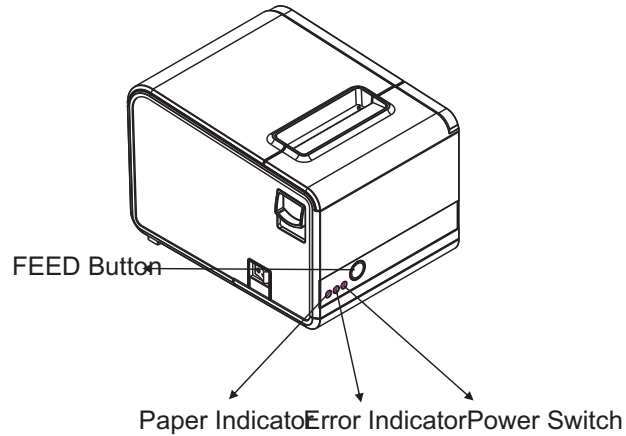

10. Functions of buttons and indicators

- (1) . FEED Button
Press to feed paper manually.
- (2) . PAPER Indicator
When this indicator is lighting as well as the ERROR indicator, printer is out of paper.
When this indicator is dim as well as the ERROR indicator, printer has paper.
When this indicator is lighting but the ERROR indicator is dim, roll paper is near end.
- (3) . ERROR Indicator
When printer is in the status of paper out, cutter error or print head overheat, this indicator is flashing according to user's defined setting
- (4) . POWER Indicator
When this indicator lights, the printer is turned on.
When this indicator dims, the printer is turned off..

11. Cutter Maintenance

Step (1)

- a. Turn off then on the printer, the printer will initialize and reset the cutter.

Step (2)

- a. Open the front cover.
- b. Wheel the gear on the cutter to make the cutter back to initial position. Open the printer cover and install roll paper correctly, then the printer works normally.

⚠ Caution: Do not open the printer cover by force, so as not to damage the print head and auto cutter.

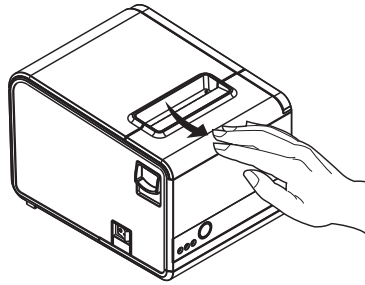

1. Open the cover by the arrow direction

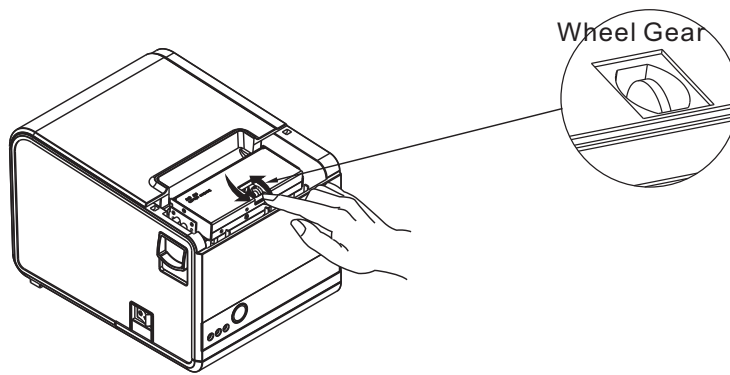

2. Turn the gear to reset the cutter

12. Professional Functions

- a. 250mm/sec high-speed printing
- b. Integration of mechanism and cutter
- c. Support connecting to WAN printing

13.Driver Installation

a. Insert the driver CD dis, run the INTEGRO setup to set up.



b. Select "Insyall Printer Driver (N)".

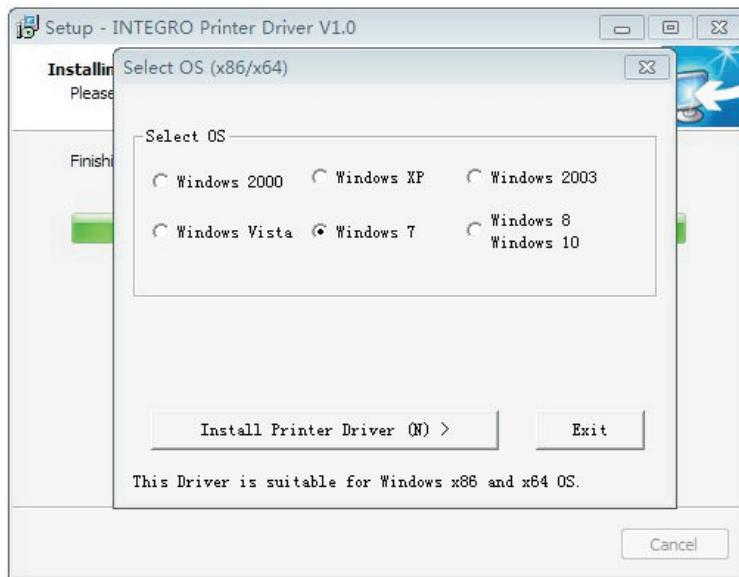

c. Select TRP80USE to continue.

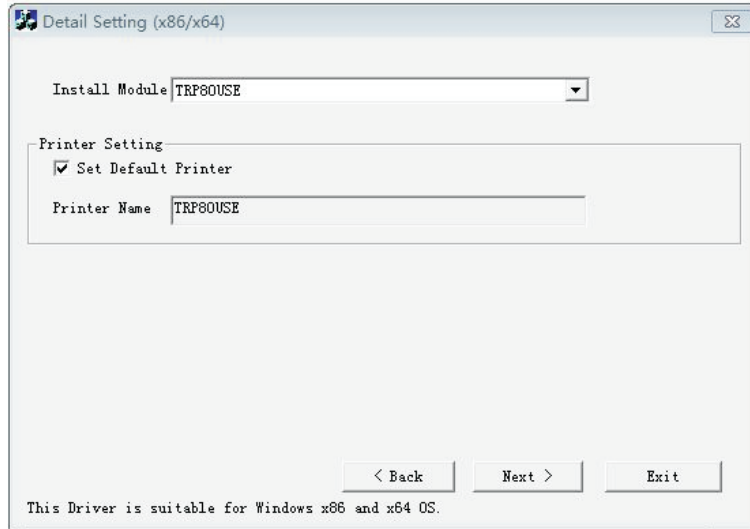

d. Select the corresponding printer port.

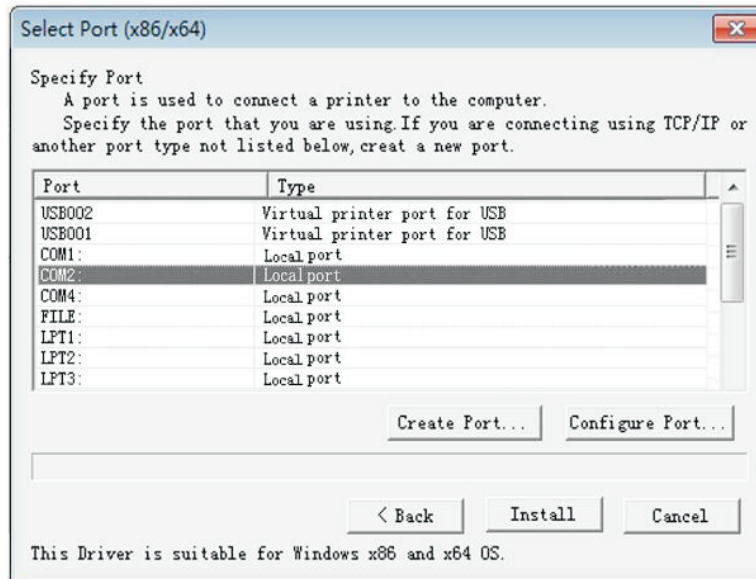

e. Installation completed.

