

8200

and

8200A

8 channel Line Mixer



API, 8301 Patuxant Range Rd., Jessup, MD 20794 301-776-7879
www.apiaudio.com

A BASIC OVERVIEW OF THE API 8200 Line Mixer

Thank you for choosing the API 8200 / 8200S 8 channel line mixer. The 8200 mixers have several unique features that will allow you to employ all the great assets of an API console without the size or cost. API's 8200 offers a discrete signal path and the ability to control levels, panning, inserts and sends. We appreciate your decision to trust your audio to API!

The **8200** is a very simple, minimum circuitry mixer. The input and output multipin connectors are all standard, incorporating the Tascam DA-series pinouts. The 8200 has 8 balanced inputs, 8 balanced insert sends, 8 balanced insert returns and connector to link with the 7600, the 7800, other 8200's and several other API products. Each channel has a mute button, an insert button and a solo button, along with a level control, a center detented panner and 2 sends. There are no master controls, as the API 7800 provides the functions of an entire console center section.

Internally, the balanced input enters through the 8 channel D-Sub input connector and goes to the insert send output, which also routes to the insert switch. The insert switch selects either the input connector or the insert return connector. From there, the balanced signal goes to an API 2510 discrete amplifier, buffering the signal to be sent to the level/panner, solo and sends. The 2510 feeds the mute switch, then to the level pot. From the level pot, the signal goes to the panner and to both sends. The solo signal is taken from the output of the panner. From those outputs, the signal goes to a summing network and out the rear connector to meet up with other 8200s or 7600s, ending up at the 7800 (see chart on Page 9 in back of manual).

Each channel is identical and is designed to accept professional levels of signal. The mixer is calibrated for a nominal +4dBu input level. Use at -10 is fine, but there will be an increase in noise when the levels are boosted to +4dBu.

The **8200A** is similar to the 8200, except that it has built in summing amps for the stereo, solo and send outputs. Several 8200s and 7600s may be linked to the 8200A, and **it then becomes the master**, using the unit's the internal summing amplifiers (there are, by design, no master controls as the user must connect this unit to an external control section). These summing amps feature stereo API 2520 outputs with transformers for the stereo bus, nominal +4dBu, summing outputs for the sends and solo at -2dBu nominal level. This option is perfect when a rack of 8200s are used as additional inputs to a console and end up patched into a couple of faders or into the mix bus. Note that the 8200A is not meant to be used with the 7800, unless the summing option is disabled.

MIXING SUGGESTION: *When starting out, set all the panners in the middle and set the level controls around 2 o'clock and let your DAW mix fly. Adjust the panners and use the level automation in the DAW for levels during the playing of the mix. The 8200's level controls can then be used to trim entire mixes, etc.*

Another use for the 8200 is plugging your Mic preamp outputs into the 8200 inputs, then take the Insert Send and plug that into your Recorder input. Next take the Recorder output and plug it into the Insert Return. Now, by pressing the Insert button, you can switch between Mic out and Tape out.

See the chart on page 9 for more ideas on setup and usage.

Input Section

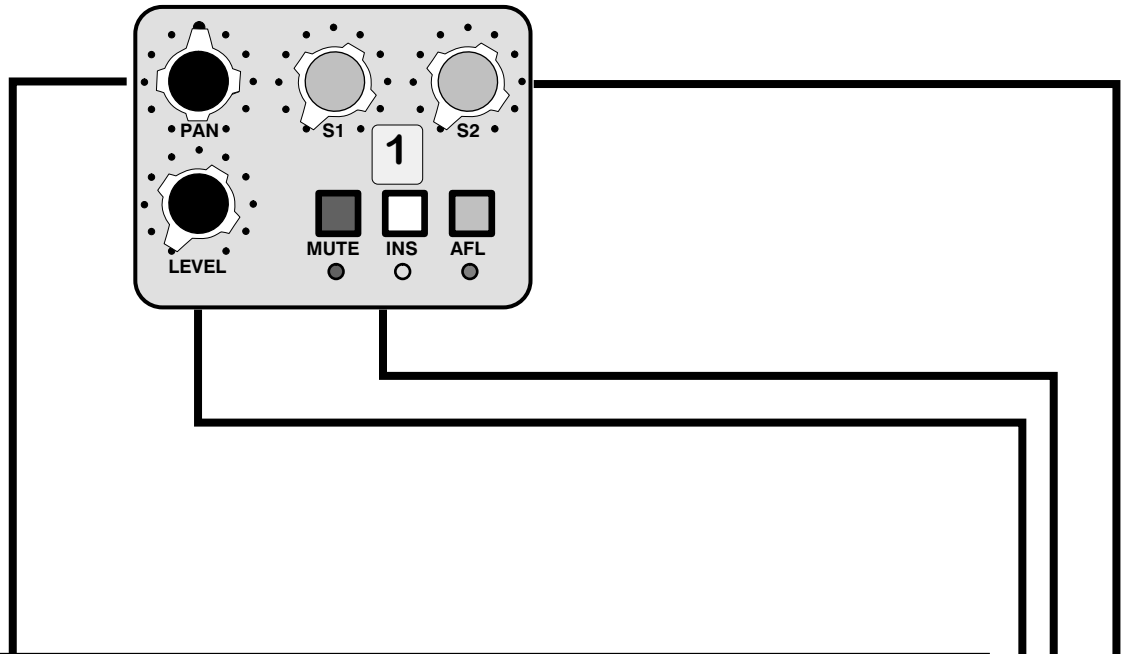

PAN:

Pans the input signal from Left to Right. It is the standard -3dB down in the center. The Solo feed is from the panner.

LEVEL:

This control adjusts the level of the signal going to the Panner and to the Sends. It also effects the Solo level.

MUTE INS AFL:

The Mute button kills the signal when pressed. It will also kill the signal to the Panner, Solo AFL and to the Sends. If the Solo or the Sends are configured for PFL, the Mute button will not effect them.

SENDS:

These two controls set the levels going to Send one (1) and Send two (2) of the 7800 Control Room Master module.

Rear Panel Power Connection, 8200

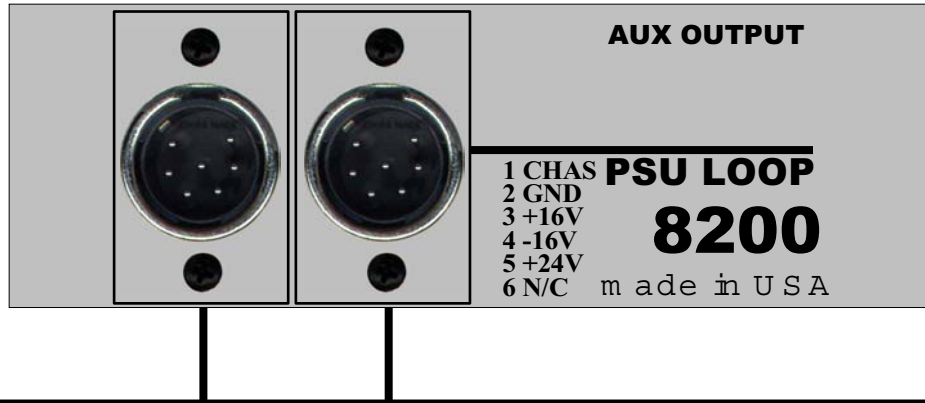

POWER:

The power supply (L100 PSU) is part of the 7800 Control Room module. Plug it into one of the connectors shown above, and take the supplied power cable loop and plug it into the other power connector. The other end of the loop then goes to either the next 8200 or into the 7800. Each 8200 comes with one power cable loop.

Rear Panel Power Connection, 8200A (INTERNAL SUMMING)

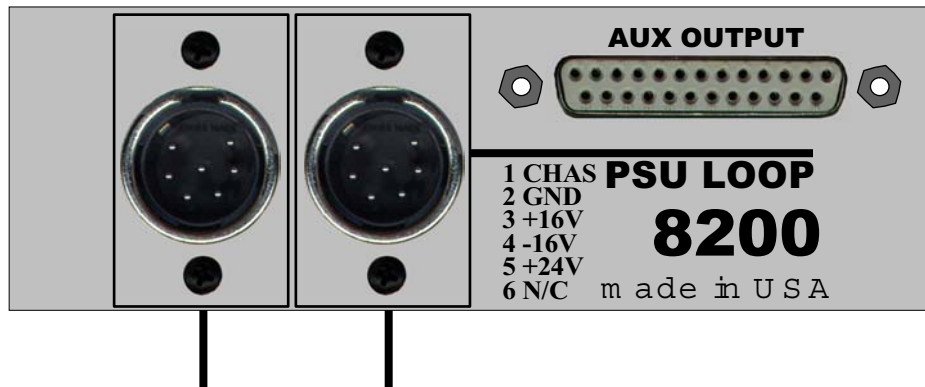

POWER:

The power supply is supplied as a separate unit, the L100. Plug it into one of the connectors shown above, and take the supplied power cable loop and plug it into the other power connector. The other end then goes to the next 8200. Each 8200 comes with one power cable loop.

AUX OUTPUT:

The AUX OUTPUT has the STEREO outputs, the SEND outputs and the SOLO outputs. Pin 13 can also be an optional relay 24 volt logic output.

EXPANSION CONNECTOR

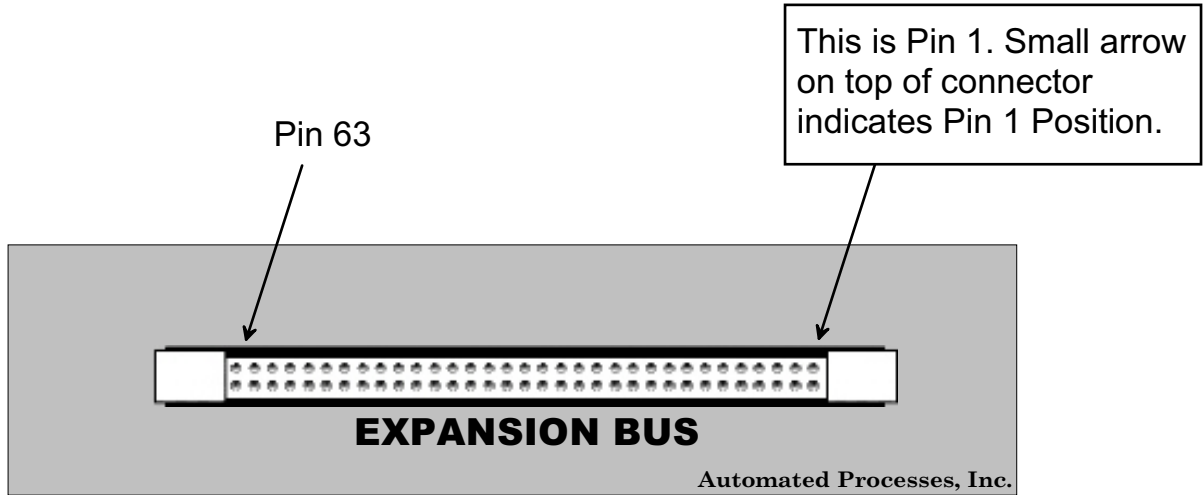

EXPANSION BUS CONNECTOR:

This connector is the summing inputs/output for the 8200. It plugs into the 7800 and to 7600s.

8200 BUS CONNECTOR PINOUT

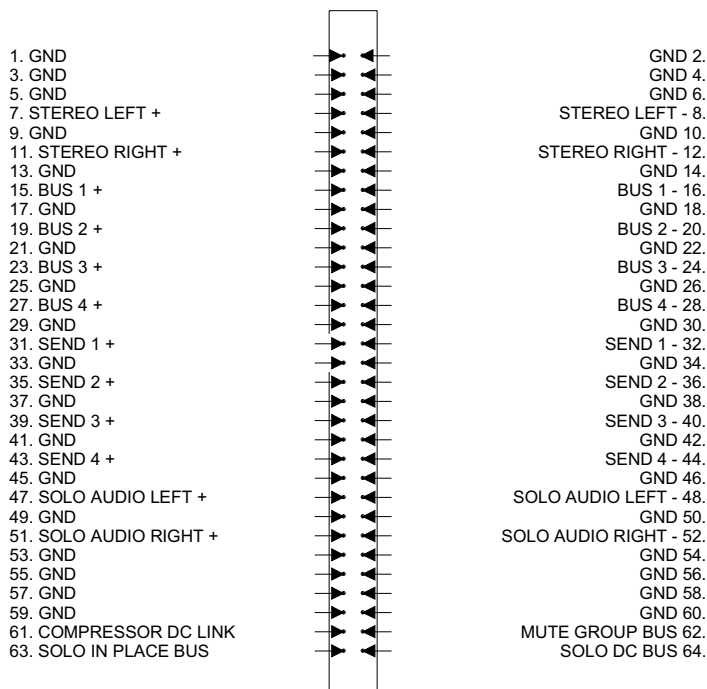

INPUT/OUTPUT SECTION, 8200

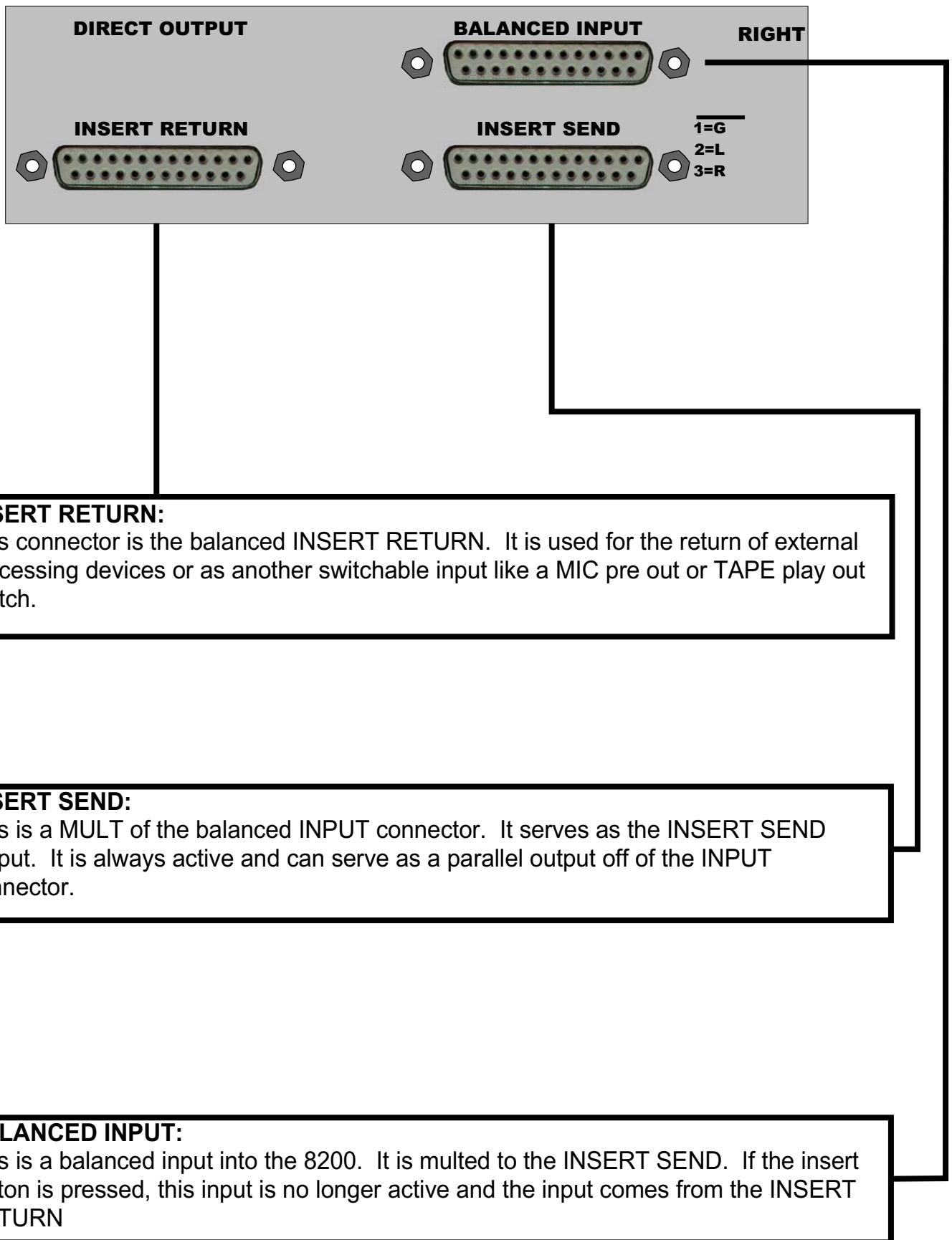

NOTE: Direct outputs are available on the standard 8200 via a header on the main pcb. For parts, cost and information on how you can modify your unit, please contact the Factory.

INPUT/OUTPUT SECTION, 8200A

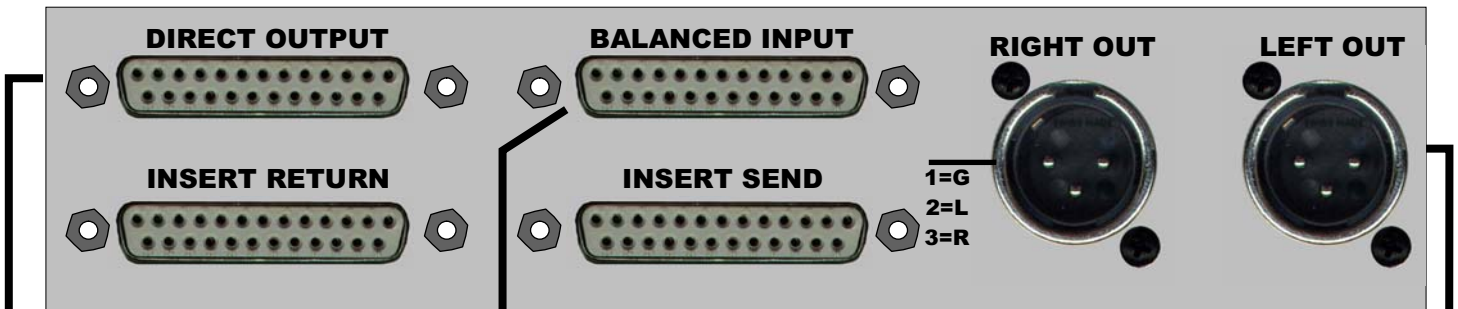

INSERT RETURN:

This connector is the balanced INSERT RETURN. It is used for the return of external processing devices or as another switchable input like a MIC pre out or TAPE play out switch.

DIRECT OUTPUT:

This connector is an output from the wipers of the level controls. It can serve as a direct output to a recorder input or a special send to a single device.

BALANCED INPUT:

This is a balanced input into the 8200. It is multed to the INSERT SEND. If the insert button is pressed, this input is no longer active and the input comes from the INSERT RETURN.

INSERT SEND:

This is a MULT of the balanced INPUT connector. It serves as the INSERT SEND output. It is always active and can serve as a parallel output off of the INPUT connector.

STEREO OUTPUT:

These XLR outputs are the STEREO outputs from the mixer stereo outputs. They use the 2520 discrete opamp and the AP2623 output transformer. The nominal output level is +4dBu. These outputs also are on the AUX OUTPUT D-sub.

CONNECTOR PINOUTS, 8200 and 8200A

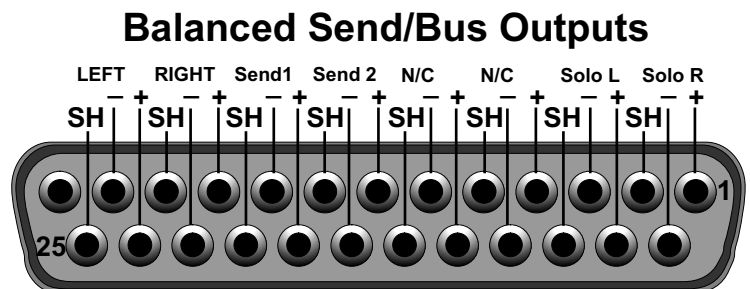
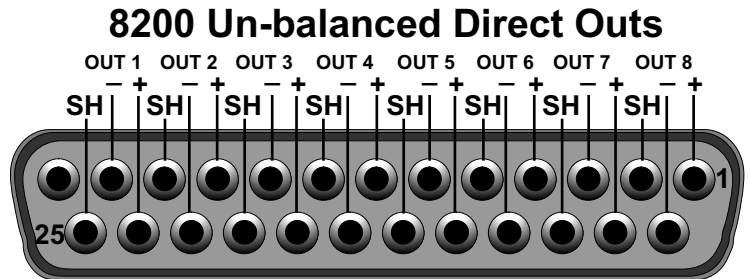
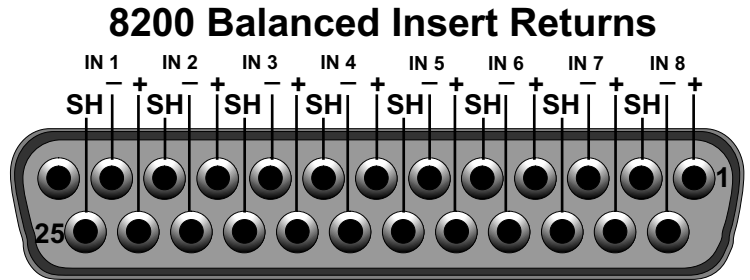
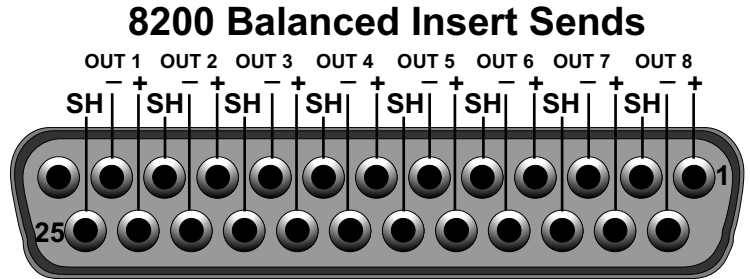
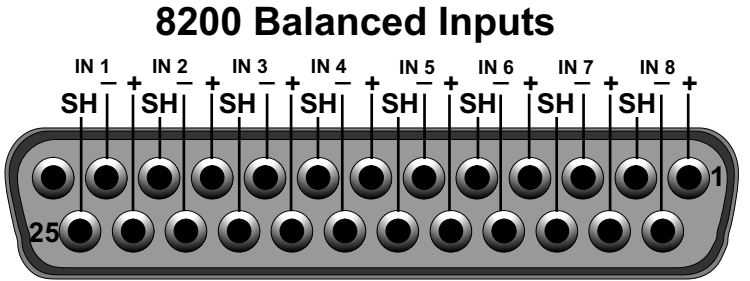
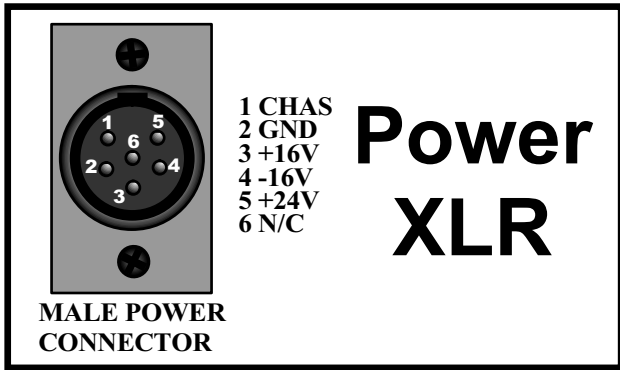
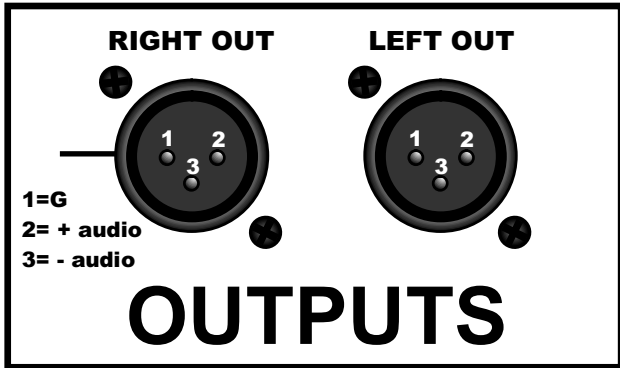

I/O HOOK UP

API 8200 BLOCK DIAGRAM

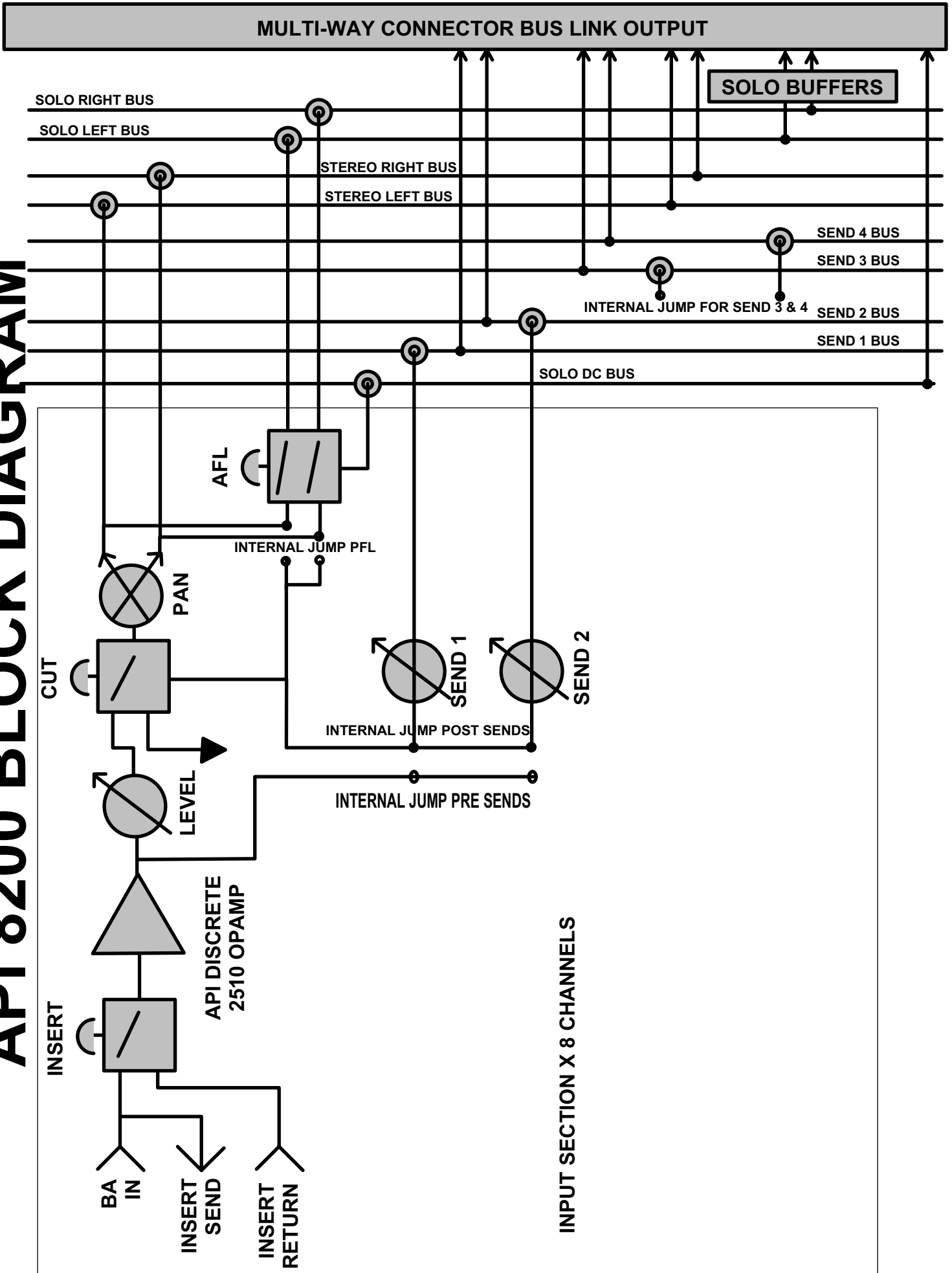

One possible hookup scenario for API 8200, 7600 and 7800 units.

NOTE: For best performance and clean cable routing, API recommends positioning your units in the order shown on this page.

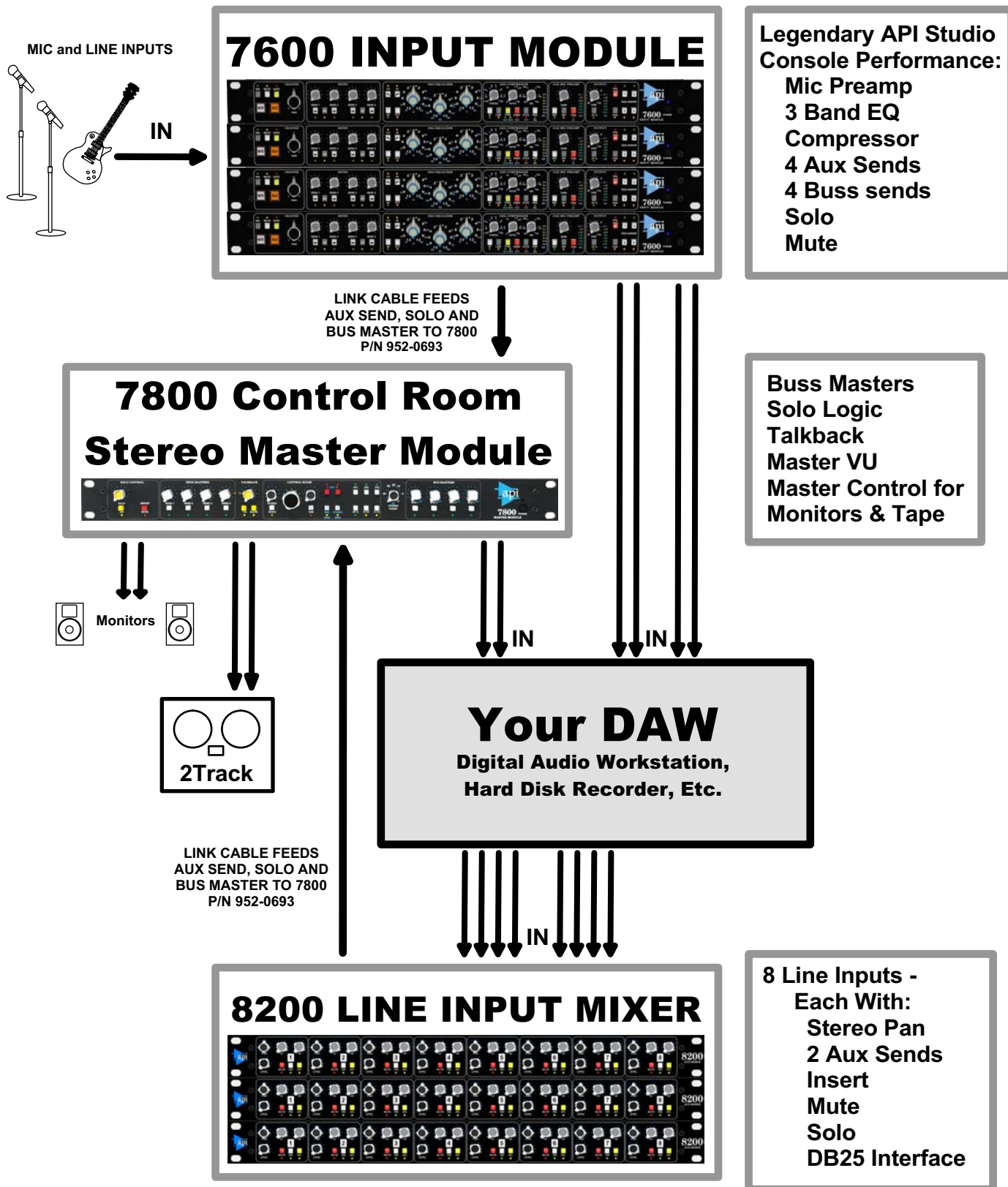

Linking 2) 7600, 3) 8200 and 1) 7800 using 2) API expansion ribbons

PSU link cables, supplied with each 8200

MALE header for additional ribbon expansion

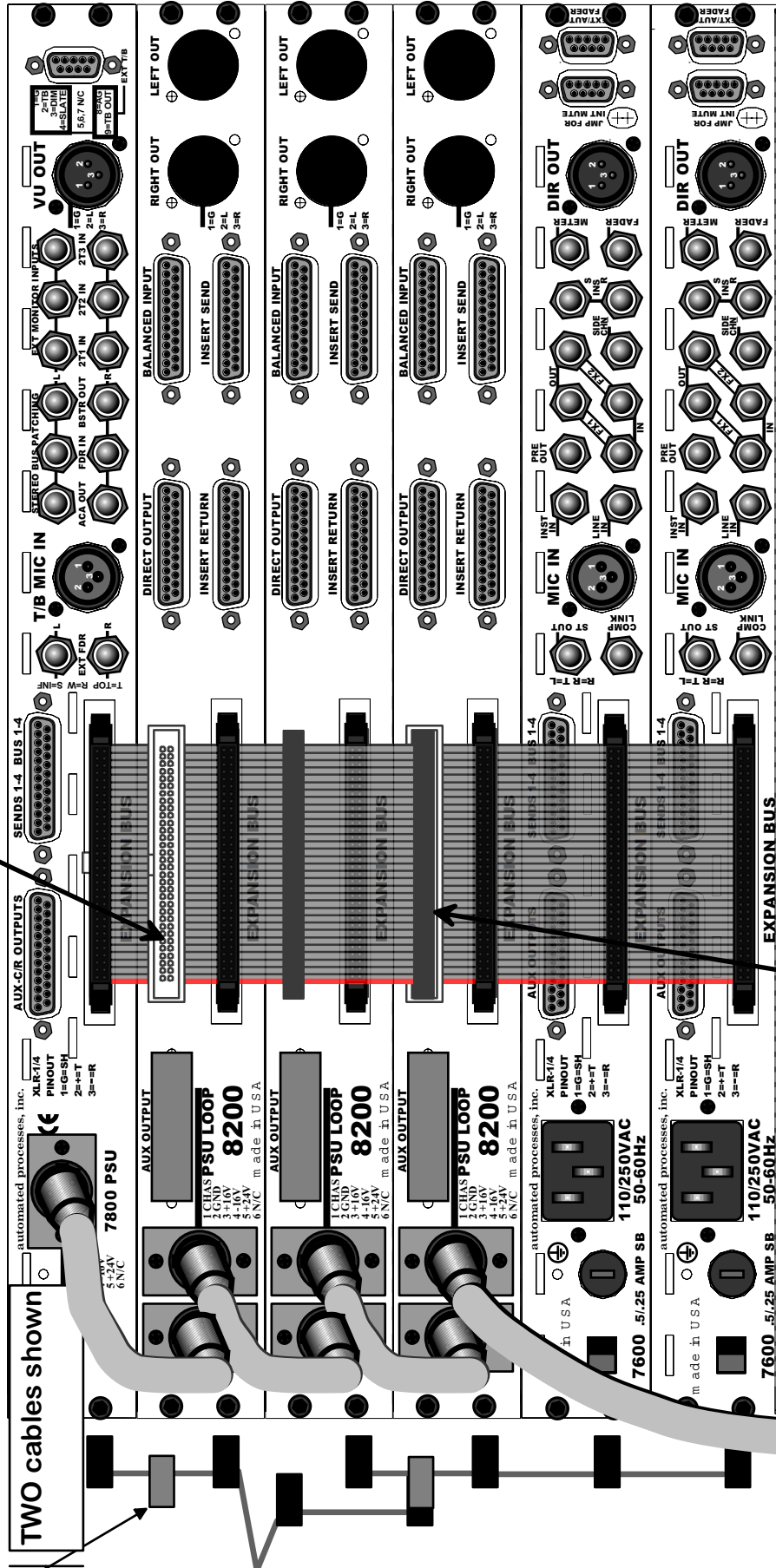

The FIRST cable links to the SECOND cable here

TO L100
POWER SUPPLY

Linking 2) 7600, 3) 8200 and 1) 8200A MASTER using 2) API expansion ribbons

PSU link cables, supplied with each 8200

Send and Solo outputs

MALE header for additional ribbon expansion

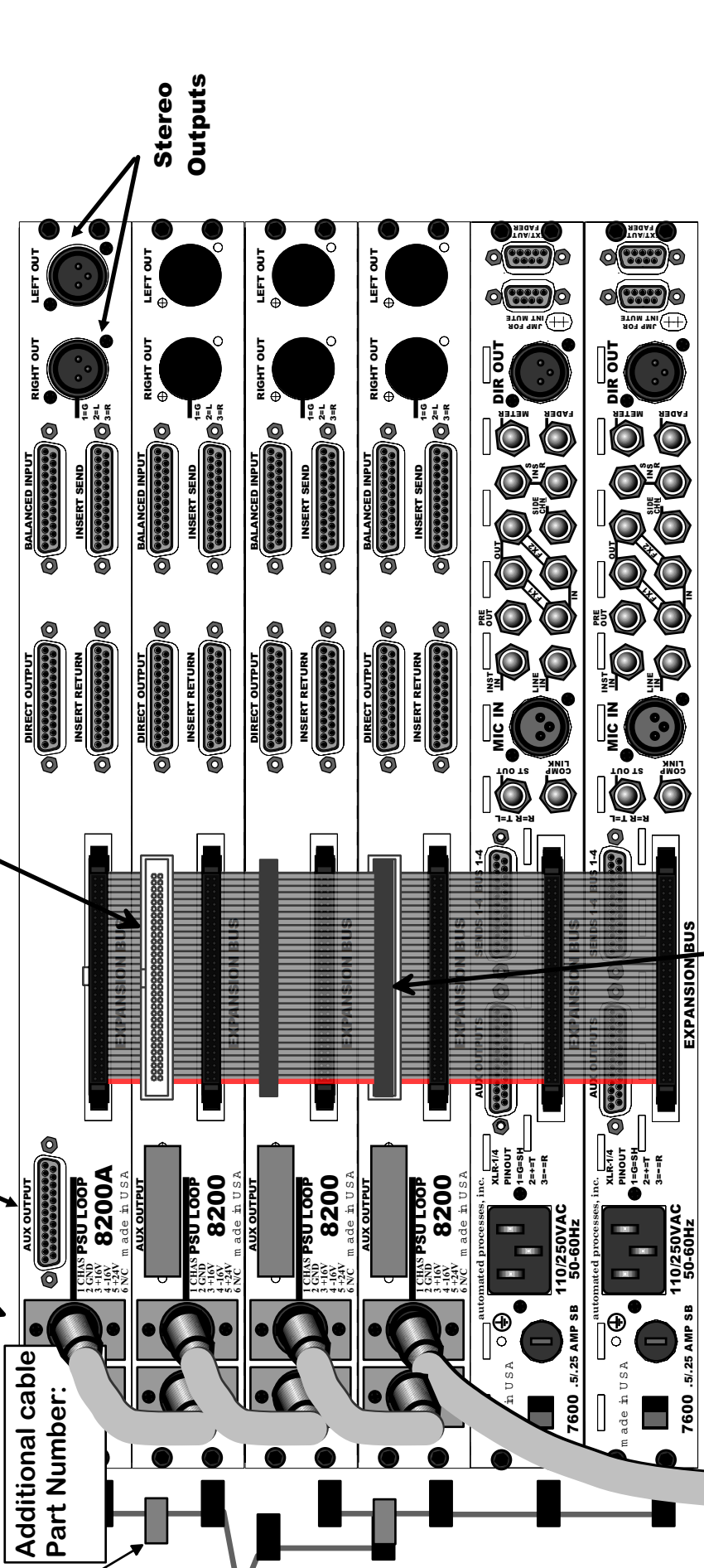

The FIRST cable links to the SECOND cable here

TO L100 POWER SUPPLY

INTERFACING THE 8200A IN THE CONTROL ROOM

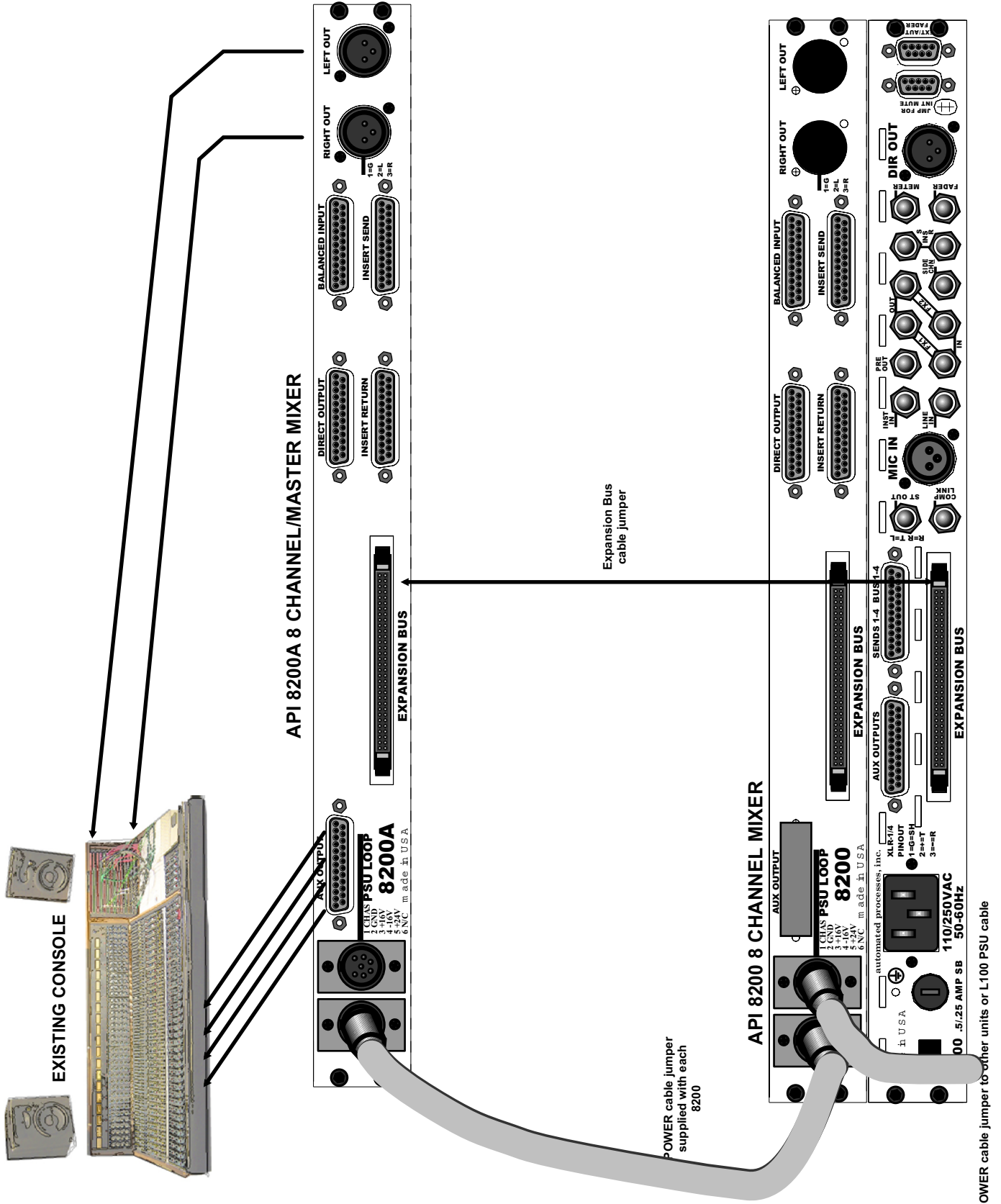

EXISTING CONSOLE

API 8200A 8 CHANNEL/MASTER MIXER

API 8200 8 CHANNEL MIXER

Expansion Bus cable jumper

POWER cable jumper supplied with each 8200

POWER cable jumper to other units or L100 PSU cable

BUS CONNECTION between 7600, 7800 & 8200

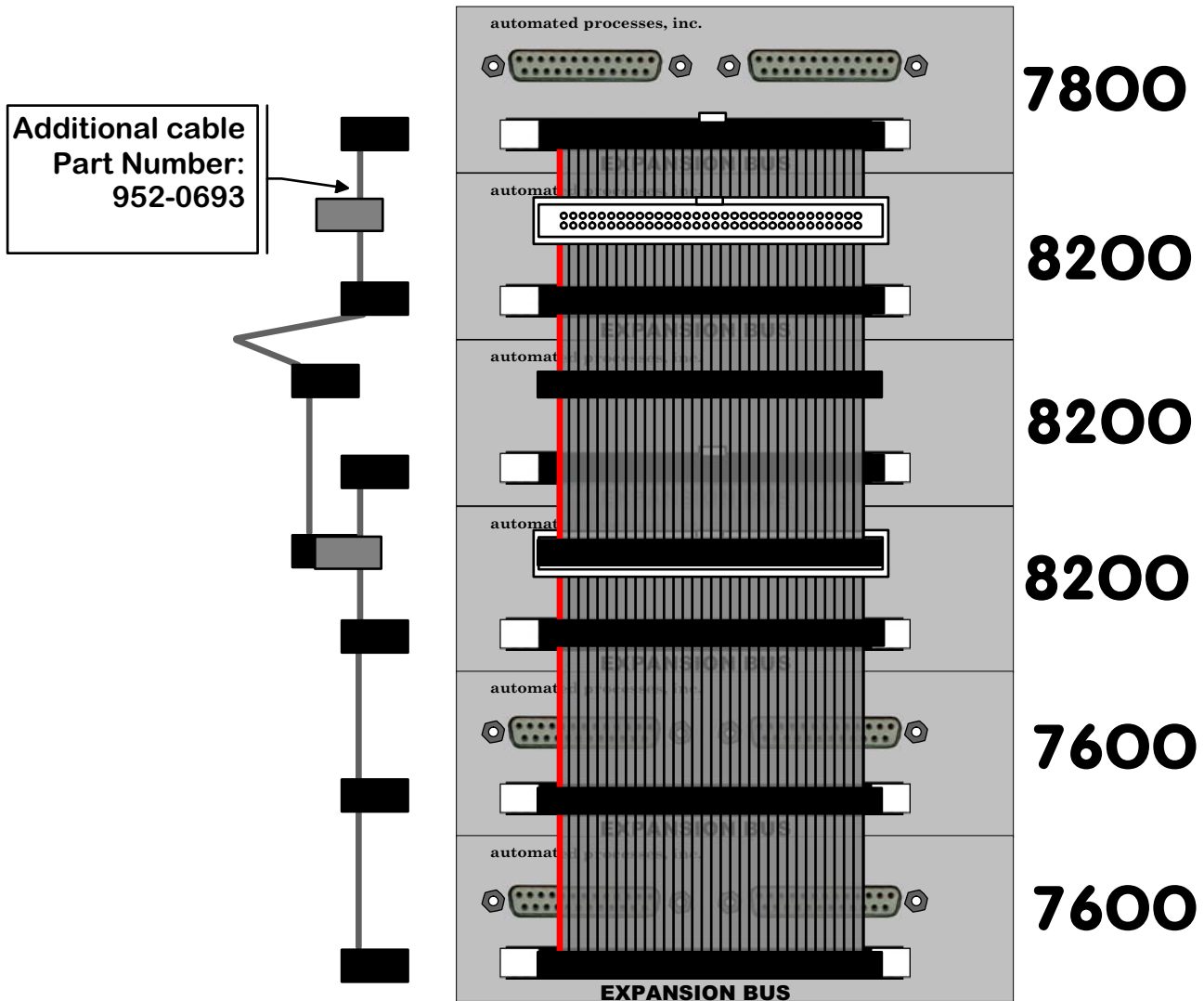
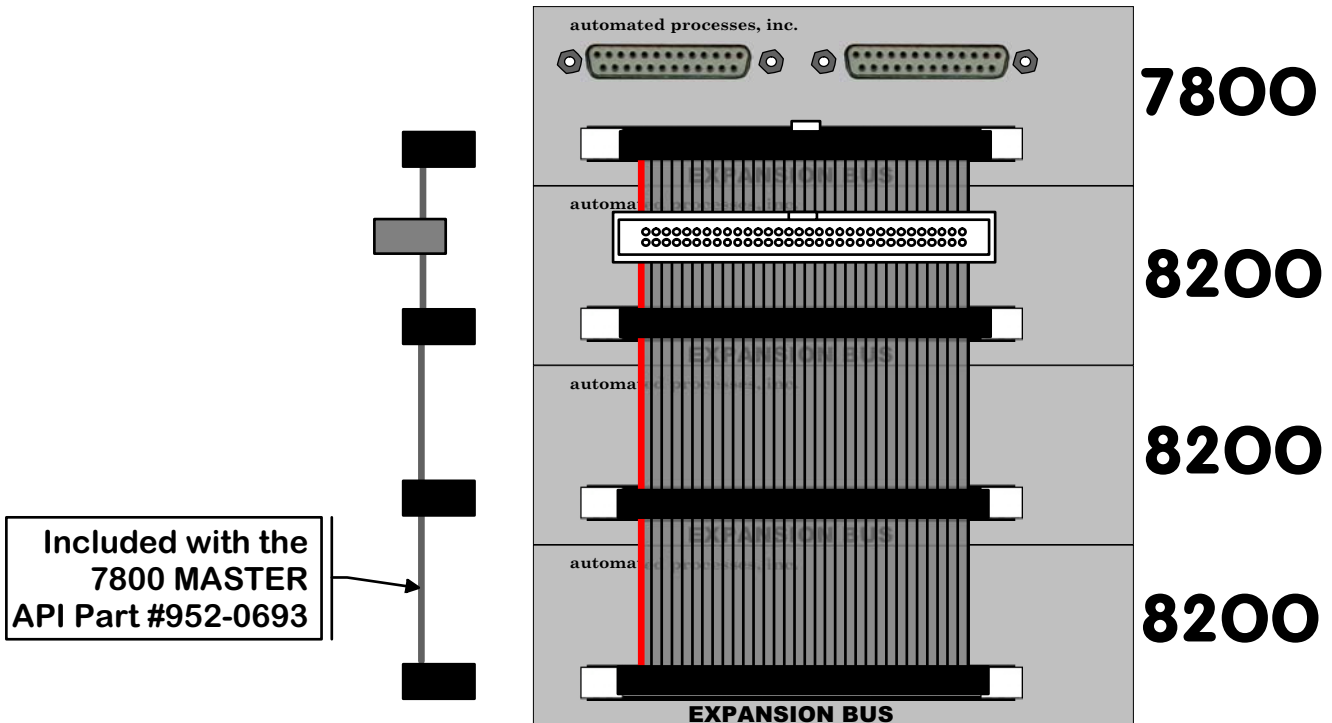

8200 / 8200A Cable Part Numbers

Direct Out Cable w/ DB25: 952-0694

Power Cable Loop: 952-0667

Bus Interconnect Ribbon: 952-0693



API is part of the ATI Group, 8301 Patuxent Range Road, Jessup, MD 20794 Tel: 301-776-7879
www.apiaudio.com



In a constant effort to improve the subtle details of our products, some amount of change is inevitable.
API reserves the right to modify or change any of the features, specifications or performance of its products without notice or obligation.