

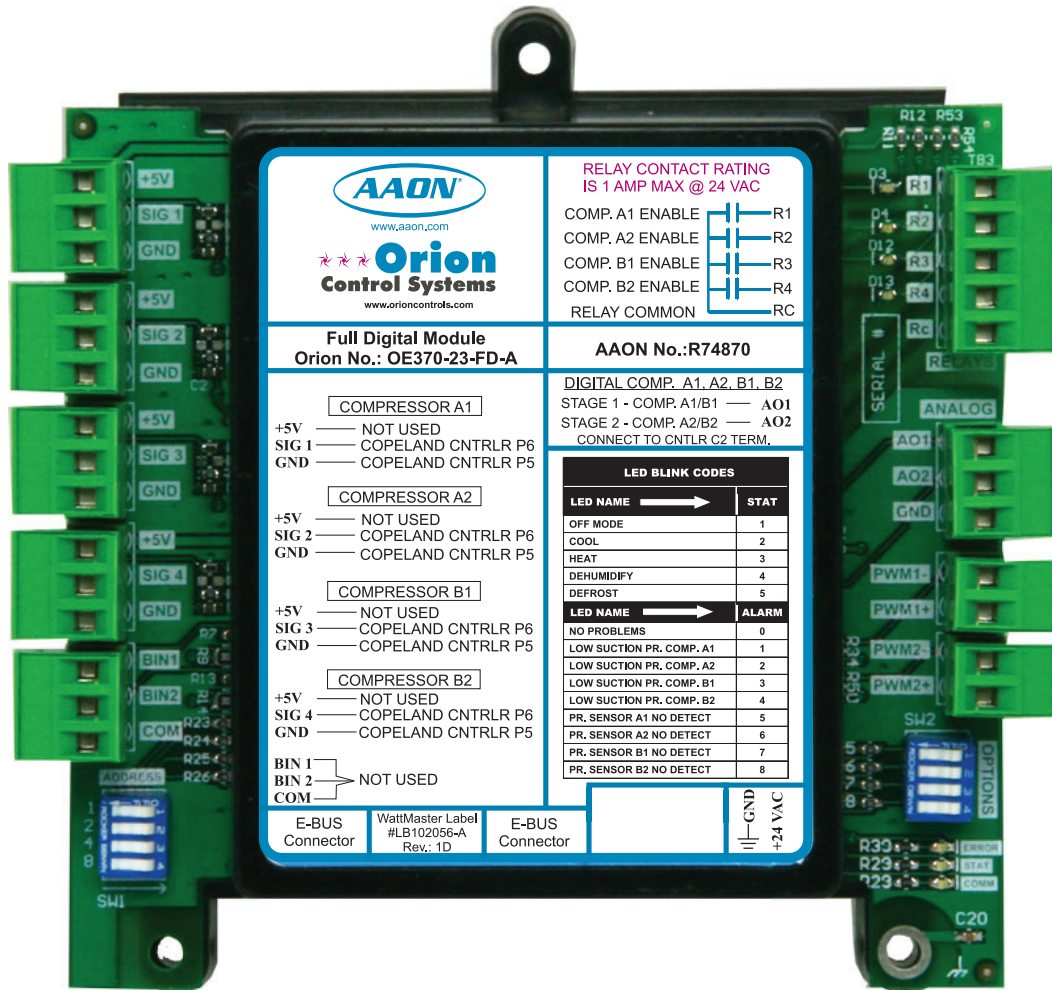

# Factory Packaged Controls

Tulsa

# Full Digital Module Technical Guide



# Table of Contents

<b>OVERVIEW</b> .....	<b>3</b>
<b>INSTALLATION AND WIRING</b> .....	<b>4</b>
Environmental Requirements .....	4
Mounting.....	4
Power Supply and Communications .....	4
Important Wiring Considerations .....	5
VCM-X Modular E-BUS Controller to Full Digital Module Wiring .....	6
<b>START-UP AND COMMISSIONING</b> .....	<b>8</b>
General.....	8
Unit Configurations.....	8
<b>MODES OF OPERATION</b> .....	<b>9</b>
Digital Stage 1 / Digital Stage 2.....	9
Off Mode.....	9
Cooling Mode .....	9
Heat Pump Heating Mode (Air to Air).....	9
Dehumidification Mode.....	9
Defrost Mode.....	9
Staging Delays .....	9
<b>TROUBLESHOOTING</b> .....	<b>10</b>
Using LEDs to Verify Operation.....	10
LED Diagnostics.....	12
Suction Pressure Transducer Testing.....	13
<b>APPENDIX</b> .....	<b>14</b>
VCM-X Controller to Full Digital Module Wiring .....	14

<b>PART NUMBER CROSS REFERENCE TABLE</b>		
<b>PART DESCRIPTION</b>	<b>ORION</b>	<b>AAON</b>
VCM-X Full Digital Module	OE370-23-FDM-A	R74870
VCM-X Modular Controller	OE332-23-VCMX-MOD-A	R90800
VCM-X Modular E-BUS Controller	OE332-23E-VCMX-MOD-A	V07150
VCM-X E-BUS Distribution Module	OE365-23-EBD-A	R82930
VCM-X Expansion Module	OE333-23-EM	R69190
VCM-X 12 Relay Expansion Module	OE358-23-12R	R69180
VCM-X One Condenser Head Pressure Module	OE370-23-HP1C	R74860
VCM-X Two Condenser Head Pressure Module	OE370-23-HP2C	R90230



[www.aon.com](http://www.aon.com)

WattMaster Controls Inc.  
 8500 NW River Park Drive · Parkville, MO 64152  
 Toll Free Phone: 866-918-1100  
 PH: (816) 505-1100 · FAX: (816) 505-1101  
 E-mail: [mail@wattmaster.com](mailto:mail@wattmaster.com)  
 Visit our web site at [www.orioncontrols.com](http://www.orioncontrols.com)  
 WattMaster Form : AA-FDM-TGD-01G

Copyright July 2016 WattMaster Controls, Inc.  
 AAON Manual Part Number: R84500  
 AAON® is a registered trademark of AAON, Inc., Tulsa, OK.  
 Neither WattMaster Controls, Inc. nor AAON®  
 assumes any responsibility for errors or omissions in this document.  
 This document is subject to change without notice.

### Overview

The Full Digital Module (OE370-23-FD-A) is a device that enables and modulates up to four digital compressors on HVAC Units controlled by the VCM-X Modular Controller (OE332-23-VCMX-MOD-A) or VCM-X Modular E-BUS Controller (OE332-23E-VCMX-MOD-A). The Full Digital Module will control the digital compressors to satisfy the cooling, dehumidification, and heat pump requirements of the VCM-X Modular series controller.

If the Full Digital Module is in the Cooling Mode or Heat Pump Heating Mode, it will modulate the compressors to maintain the appropriate Supply Air Temperature Setpoint. If the module is in the Dehumidification Mode, it will modulate compressors to maintain the Coil Suction Temperature Setpoint. If the module is in the Heat Pump Heating Mode, the module can also monitor a signal for a Defrost Cycle from the VCM-X Modular series controller if a One Condenser Head Pressure Module (OE370-23-HP1C) is also installed.

The Full Digital Module is connected to the VCM-X Modular Controller using the E-BUS Distribution Module (OE365-23-EBD). The Full Digital Module can also be directly connected to the VCM-X Modular E-BUS Controller. Either connection allows the Full Digital Module to receive setpoints and monitor the Supply Air Temperature from the VCM-X Modular series controller. The Full Digital Module requires a 24 VAC power connection with an appropriate VA rating.

**NOTE:** The Full Digital Module contains no user-serviceable parts. Contact qualified technical personnel if your module is not operating correctly.

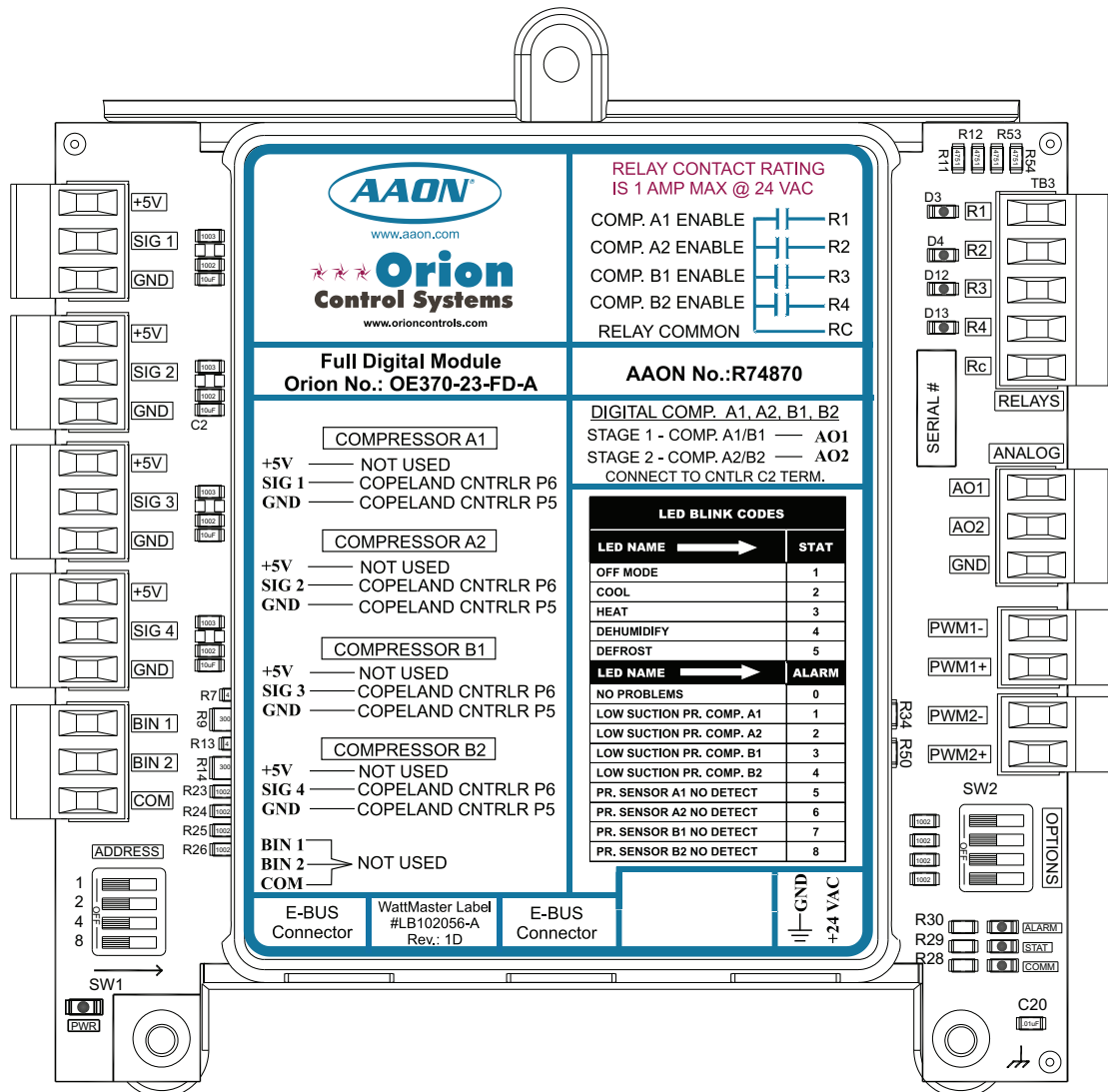

Figure 1: Full Digital Module

# Full Digital Module

## Installation and Wiring

### Environmental Requirements

The Full Digital Module needs to be installed in an environment which can maintain a temperature range between -30°F and 150°F and not exceed 90% RH levels (Non-Condensing).

### Mounting

The Full Digital Module is housed in a plastic enclosure. It is designed to be mounted by using the 3 mounting holes in the enclosure base. It is important to mount the module in a location that is free from extreme high or low temperatures, moisture, dust, and dirt. Be careful not to damage the electronic components when mounting the module.

See **Figure 2** for Module dimensions (dimensions are in inches).

### Power Supply and Communications

The Full Digital Module is connected to the E-BUS Distribution Module with a modular HSSC cable to provide communications from the VCM-X Modular Controller. The E-BUS Distribution Module uses WattMaster Control's standard I<sup>2</sup>C modular cable to connect with the VCM-X Modular Controller, VCM-X Expansion Module, or 12-Relay Expansion Module.

The Full Digital Module can also be directly connected to the VCM-X Modular E-BUS Controller, bypassing the use of the E-BUS Distribution Module.

The Full Digital Module requires a 24 VAC power supply with an appropriate VA rating.

**WARNING:** Observe polarity! All boards must be wired GND-to-GND and 24 VAC-to-VAC. Failure to observe polarity could result in damage to the boards.

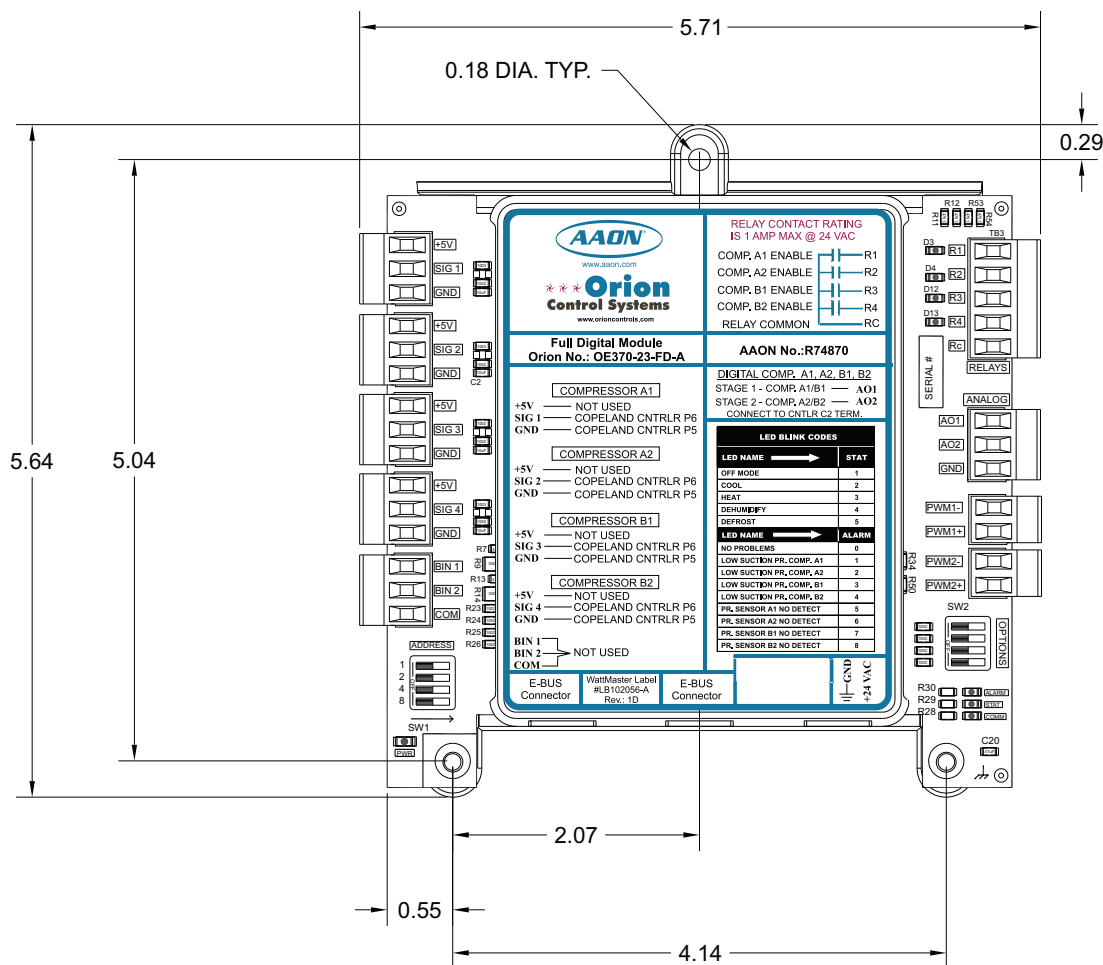

**Note:** Height is 1.49 inches.

**Figure 2: Full Digital Module Dimensions**

# Full Digital Module Installation and Wiring

## Important Wiring Considerations

Please carefully read and apply the following information when wiring the Full Digital Module:

1. The 1 to 5 VDC signals for the Copeland Compressor Speed need to use 18-gauge shielded twisted pair cable, and the Drain wire must be the GND signal.
2. All 24 VAC wiring must be connected so that all ground wires remain common. Failure to follow this procedure can result in damage to the module and connected devices.
3. All wiring is to be in accordance with local and national electrical codes and specifications.

4. Be sure that all wiring connections are properly inserted and tightened into the terminal blocks. Do not allow wire strands to stick out and touch adjoining terminals. This could potentially cause a short circuit.
5. Be sure all modular wiring harness connectors are seated firmly in their respective modular connectors on the circuit board.

**NOTE:** The Compressor Relays on the Full Digital Module are used rather than the relay outputs on the VCM-X Modular series controller.

**WARNING:** Be sure all controllers and modules are powered down before connecting or disconnecting HSSC cables.

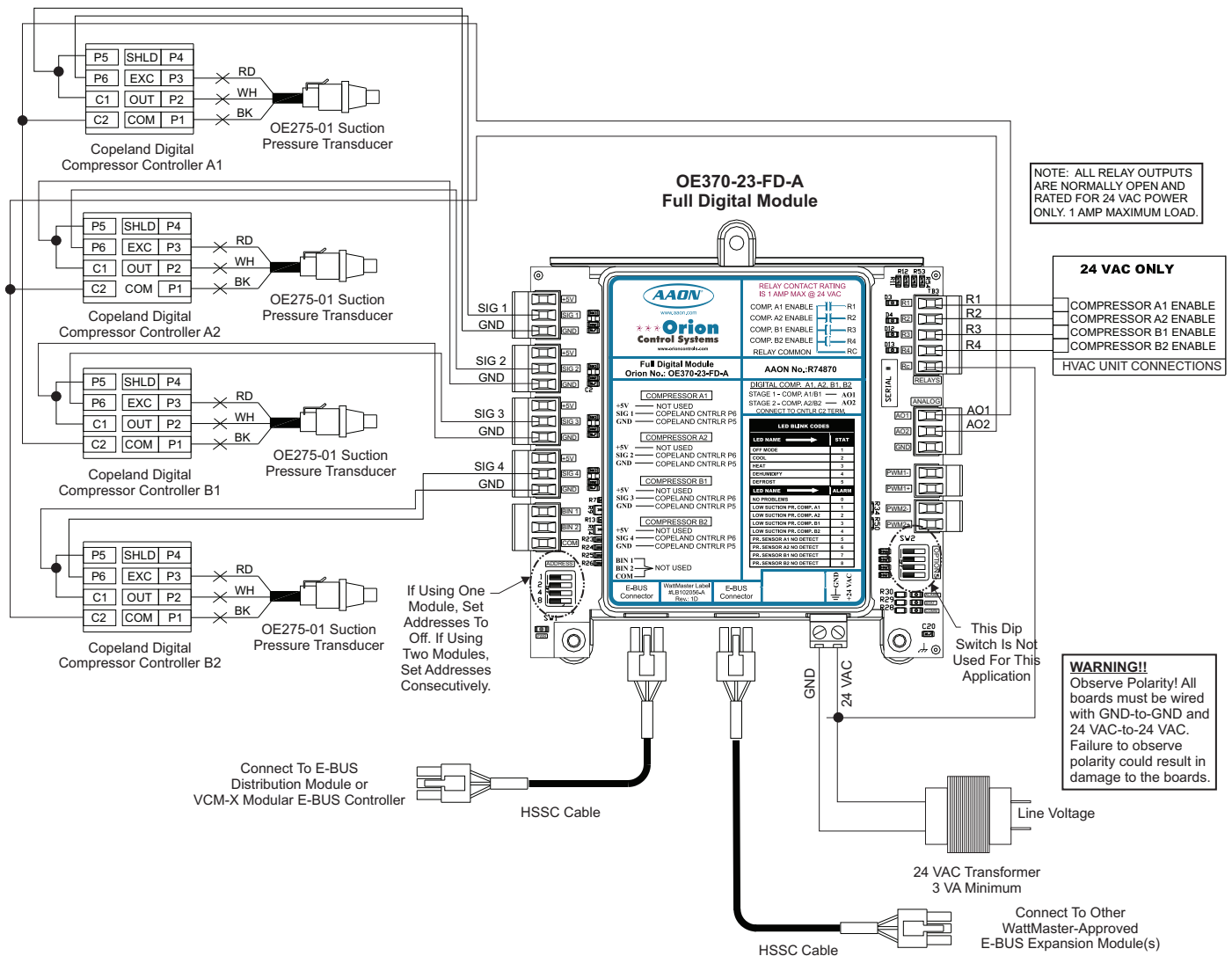

Figure 3: Full Digital E-BUS Connection Wiring

# Full Digital Module

## Installation and Wiring

### VCM-X Modular E-BUS Controller to Full Digital Module Wiring

The Full Digital Module directly connects to the VCM-X Modular E-BUS Controller using a modular HSSC cable. The Full Digital Module requires a 24 VAC power connection with an appropriate VA rating. See Figure 4 below for wiring.

Any E-BUS Module can be connected to the E-BUS Controller's E-BUS port or can be daisy-chained together using HSSC cables.

**NOTE:** Contact Factory for the correct HSSC cable length for your application. Cables are available in 1/2 and 3 meter lengths and 100 and 150 foot lengths.

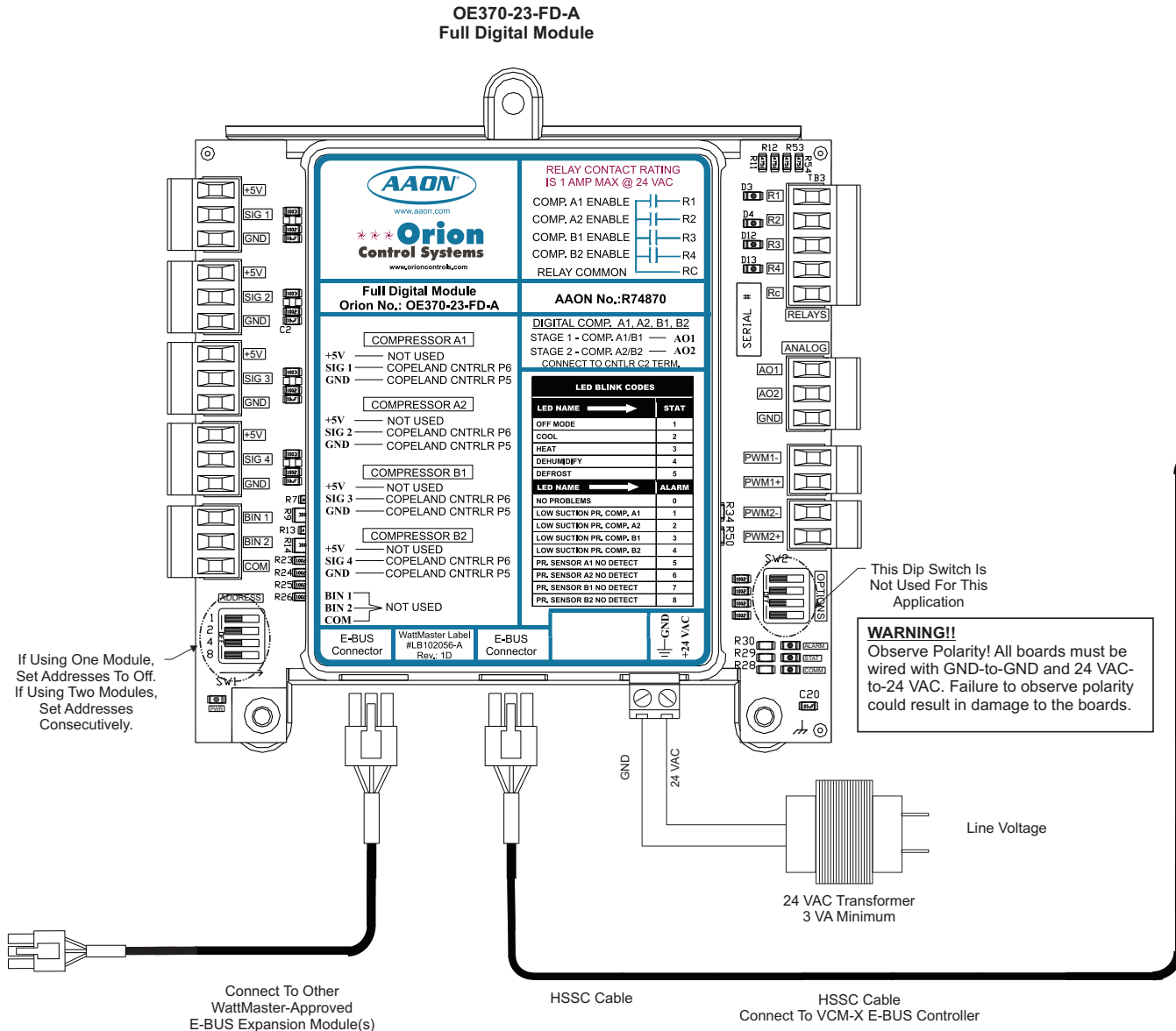

Figure 4: VCM-X Modular E-BUS Controller to Full Digital Module Wiring Diagram

# Full Digital Module Installation and Wiring

**WARNING:** Be sure all controllers and modules are powered down before connecting or disconnecting HSSC cables.

For Stand Alone Applications, Connect To System Manager. For Network Applications Connect To Next Controller And/Or MiniLink PD On Local Loop.

Local Loop  
RS-485  
9600 Baud

All Comm Loop Wiring Is  
Straight Thru  
T to T, R to R & SHLD to SHLD

HSSC Cable Connect To  
VCM-X E-BUS Port

See Individual  
Component Wiring  
Diagrams For  
Detailed Wiring Of  
Analog Inputs And

Jumpers

Splice If Required

OE271  
Static Pressure  
Transducer

Connect FRP Tubing To High Pressure  
Port (Bottom Tube) and Route To Static  
Pressure Pickup Probe Located In Unit  
Discharge. Leave Port Marked "Lo" Open  
To Atmosphere

## OE332-23E-VCMX-MOD-A VCM-X Modular E-BUS Controller

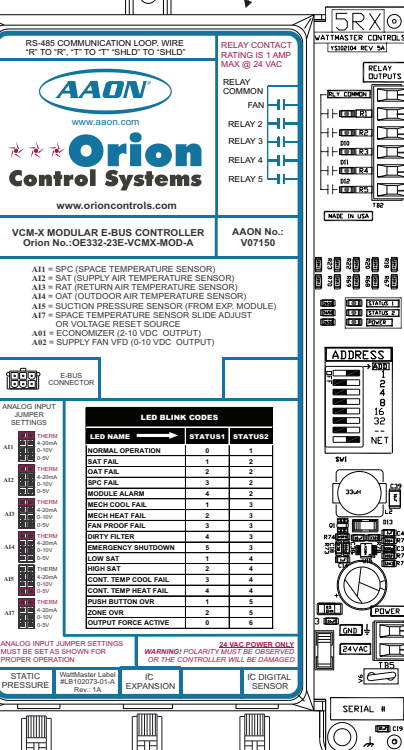

**Note:**  
All Relay Outputs Are Normally Open And  
Rated For 24 VAC Power Only.  
1 Amp Maximum Load.

R - 24VAC  
G - Fan ON/OFF Only

**Relay Output Contacts  
R2 Through R5 May Be User-Configured  
For The Following:**

- 1 - Heating Stages
- 2 - Cooling Stages
- 3 - Warm-up Mode Command (VAV Boxes)
- 4 - Reversing Valve (Air To Air Heat Pumps)
- 5 - Reheat Control (Dehumidification)
- 6 - Exhaust Fan Interlock
- 7 - Preheater For Low Ambient Protection
- 8 - Alarm
- 9 - Override
- 10 - Occupied
- 11 - OA Damper
- 12 - Heat Wheel
- 13 - Emergency Heat

Note: 1.) When Using the HP2C Module, All Compressors Will Be Wired From the Protection Module, Not the VCM-X Controller.  
Note: A Total Of 20 Relays Are Available By Adding Relay Expansion Modules. All Expansion Module Relay Outputs Are User Configurable As Listed Above.

GND  
24VAC  
Line Voltage

Size Transformer For Correct  
Total Load.  
VCM-X Modular Controller = 8

**Warning:**  
24 VAC Must Be Connected So That All Ground  
Wires Remain Common. Failure To Do So Will  
Result In Damage To The Controllers.

Figure 4, cont.: VCM-X E-BUS Controller to Full Digital Module Wiring Diagram

## Start Up and Commissioning

### General

In order to have a trouble free start-up, it is important to follow a few simple procedures. Before applying power for the first time, it is very important to run through a few simple checks.

One of the most important checks to make before powering up the system for the first time is to make sure that the VCM-X Modular or VCM-X Modular E-BUS Controller is configured properly for your application. Refer to the *VCM-X Controller Technical Guide* or *VCM-X Modular E-BUS Controller Technical Guide* for more information. A handheld Modular Service Tool, Modular System Manager, or System Manager Touch Screen connected to the VCM-X Modular or VCM-X Modular E-BUS Controller will allow you to configure your application. Refer to the *VCM-X / RNE Operator's Interfaces SD Technical Guide* or *System Manager TS II Technical Guide* for more information.

Check all wiring leads at the terminal block for tightness. Be sure that wire strands do not stick out and touch adjacent terminals. Confirm that all sensors required for your system are mounted in the appropriate location and wired into the correct terminals.

**WARNING:** Observe polarity! All boards must be wired GND-to-GND and 24 VAC-to-VAC. Failure to observe polarity could result in damage to the boards.

UNIT CONFIGURATIONS						
PERMUTATION	SYSTEM A		SYSTEM B		HARDWARE	VCM-X WSHF CONFIGURATION
	Comp A1	Comp A2	Comp B1	Comp B2		
	Relay 1	Relay 2	Relay 3	Relay 4		
1	On/Off	On/Off			Use VCM-X Modular Series Controller Only	2 Compressors
2	Digital	On/Off			Use VCM-X Modular Series Controller Only	2 Compressors Digital Compressor
3	Digital	Digital			Use VCM-X Modular Series Controller and Full Digital Module	2 Compressors Full Digital
4	On/Off	On/Off	On/Off	On/Off	Use VCM-X Modular Series Controller Only	4 Compressors
5	Digital	On/Off	On/Off	On/Off	Not Available	Not Available
6	Digital	On/Off	Digital	On/Off	Use VCM-X Modular Series Controller Only	4 Compressors Digital Compressor
7	Digital	Digital	Digital	Digital	Use VCM-X Modular Series Controller and Full Digital Module	4 Compressors Full Digital
<p>In the <i>Cooling Mode</i>, the Compressors will stage in the following order:</p> <p><b>Permutations 1, 2 &amp; 3:</b> Compressor A1 -&gt; Compressor A2  <b>Permutations 4:</b> Compressor A1 -&gt; Compressor A2 -&gt; Compressor B1 -&gt; Compressor B2  <b>Permutations 6:</b> Compressor A1 &amp; Compressor A2 -&gt; Compressor B1 -&gt; Compressor B2  <b>Permutations 7:</b> Compressor A1 &amp; Compressor A2 -&gt; Compressor B1 &amp; Compressor B2</p> <p>In the <i>Dehumidification Mode</i>, the Compressors will stage in the following order:</p> <p><b>Permutation 4:</b> Compressor A1 &amp; Compressor A2 -&gt; Compressor B1 -&gt; Compressor B2</p> <p>All other permutations in the Dehumidification Mode stage as described in the Cooling Mode.</p>						

**Table 1: Unit Configurations Chart**



---

---

**NOTE:** See Unit Configurations Chart on page 10 for more information about compressor staging.

---

---

## **Digital Stage 1 / Digital Stage 2**

On units with two Digital Scroll Compressors, the first compressor (A1) will be designated as Digital Stage 1 and the second compressor (A2) will be designated as Digital Stage 2.

On units with four Digital Scroll Compressors, there may be instances where compressor numbers on the module do not correlate with the mechanical compressors' numbers. Therefore, Digital Stage 1 refers to the first set of Digital Scroll Compressors (A1/B1) that will stage on together and Digital Stage 2 refers to the second set of Digital Scroll Compressors (A2/B2) that will stage on together. Please refer to AAON's wiring diagram for specific wiring of the unit.

## **Off Mode**

The Full Digital Module will be in the Off Mode when no signal is being received from the VCM-X Modular series controller to run the compressors.

## **Cooling Mode**

When a Cool Signal is received, the Full Digital Module will go into Cooling Mode. At this point, Compressor A1 (and B1\*) will energize and Digital Stage 1 Analog Output will modulate as necessary to maintain the Supply Air Temperature at the Active Supply Air Setpoint that is broadcast from the VCM-X Modular series controller.

When Digital Stage 1 reaches 100%, a stage up timer is started. If Digital Stage 1 stays at 100% for the Stage Up timer, Compressor A2 (and B2\*) will energize and both Digital Stage 1 and Digital Stage 2 outputs will go to 50% and begin to modulate together.

If both systems are energized and they go below 30% and the Supply Air is below the Supply Air Setpoint by the Cooling Stage Window value, the stage down timer is started. If the systems remain below 30% for the duration of the stage down timer, Digital Stage 2 will deactivate and Digital Stage 1 will go to 60%. Digital Stage 1 will stage down if it is at 0% for the duration of the stage down timer.

\* If configured for 4 modulating compressors.

## **Heat Pump Heating Mode (Air to Air)**

Heating Mode works the same as Cooling Mode except the Reversing Valve is switched and the sequence is opposite. Compressors modulate up when below the Heating Supply Air Setpoint and modulate down when above the setpoint.

## **Dehumidification Mode**

In Dehumidification Mode, compressors will be controlled to maintain the Suction Pressure Temperature Setpoint. Digital Stage 1—Compressor A1 (and B1\*) will modulate up to 100% before Digital Stage 2—Compressor A2 (and B2\*) can be energized. When Digital Stage 2 is energized, Digital Stage 1 will be locked at 100%.

\* If configured for 4 modulating compressors.

## **Defrost Mode**

In Defrost Mode, if only Digital Stage 1 is energized, it will go to 100% and the reversing valve will deactivate. If both Digital Stage 1 & Digital Stage 2 are energized, they will both go to 100% and the reversing valve will be deactivated. The duration for Defrost Mode is determined by the VCM-X Modular series controller.

---

---

**NOTE:** Defrost Mode is only available if a One Condenser or Two Condenser Head Pressure Module is installed.

---

---

## **Staging Delays**

Staging Delays minimum run times and minimum off times are sent from the VCM-X Modular series controller.

### Using LEDs to Verify Operation

The Full Digital Module is equipped with LEDs that can be used to verify operation and perform troubleshooting. There are LEDs for communication, operation modes, and diagnostic codes. The module has seven LEDs—one used for power, one used for operation status, one used for alarms, and four used for the compressor relays. See **Figure 5** for the LED locations. The LEDs associated with these inputs and outputs allow you to see what is active without using a voltmeter. The LEDs and their uses are as follows:

#### ① Status LEDs

“**COMM**” - The COMM LED lights up to indicate Communications between the module and the VCM-X Modular series controller. If Communications are established, the COMM LED will blink.

“**ALARM**” - This is the diagnostic blink code LED. It will light up and blink out diagnostic codes. See **Table 2** for Diagnostic Blink Code descriptions. The blink code descriptions are also located on the module’s front cover.

No. of Blinks	Status
0	No Problems
1	Low Suction Pressure Compressor A1
2	Low Suction Pressure Compressor A2
3	Low Suction Pressure Compressor B1
4	Low Suction Pressure Compressor B2
5	Pressure Sensor A1 Not Detected
6	Pressure Sensor A2 Not Detected
7	Pressure Sensor B1 Not Detected
8	Pressure Sensor B2 Not Detected
9	No Communication

**Table 2: ALARM LED Blink Codes**

“**STAT**” - This is the status blink code LED. It will light up and every 10 seconds will blink the status mode that the module is currently operating under. See **Table 3** for Status Blink Code code descriptions. The blink code descriptions are also located on the module’s front cover.

No. of Blinks	Status
1	Off Mode
2	Cool Mode
3	Heat Mode
4	Dehumidify Mode
5	Defrost Mode

**Table 3: STAT LED Blink Codes**

② Compressor LEDs

“R1” - This LED will light up when Compressor A1 is enabled and will stay lit as long as Compressor A1 is active.

“R2” - This LED will light up when Compressor A2 is enabled and will stay lit as long as Compressor A2 is active.

“R3” - This LED will light up when Compressor B1 is enabled and will stay lit as long as Compressor B1 is active.

“R4” - This LED will light up when Compressor B2 is enabled and will stay lit as long as Compressor B2 is active.

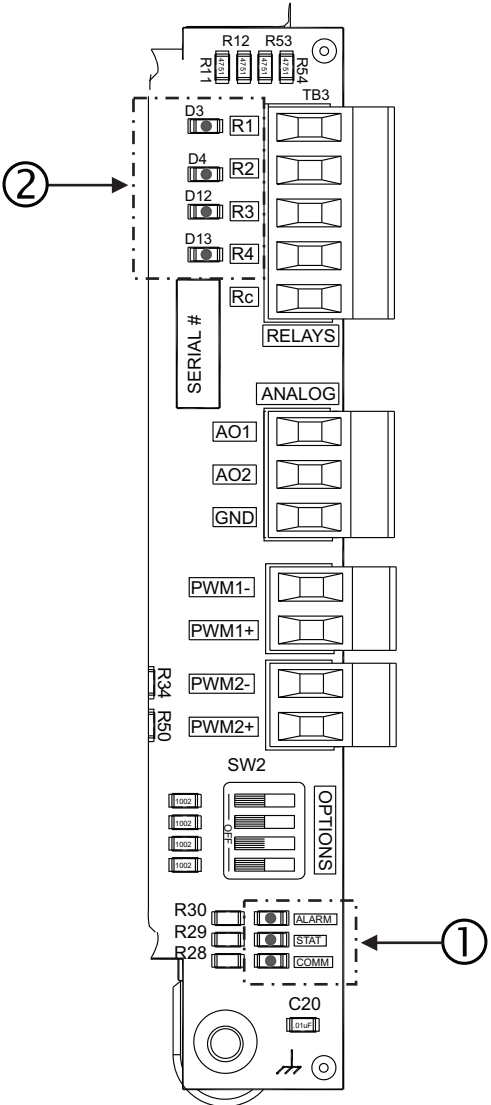

Figure 5: LED Locations

## Troubleshooting

---

### LED Diagnostics

---

**“PWR” LED:** When the Full Digital Module is powered up, the PWR LED (located below the address switches) should light up and stay on continuously. If it does not light up, check to be sure that the power wiring is connected to the board, the connections are tight, and the VCM-X Modular series controller is powered. If after making all these checks, the PWR LED does not light up, the module is probably defective.

**“COMM” LED:** The COMM LED lights up to indicate Communications between the module and the VCM-X Modular series controller. If the COMM LED does not blink, then communications have not been established. Check the connection between the VCM-X Modular Controller, the VCM-X Modular E-BUS Controller, the E-BUS Distribution Module, and the Full Digital Module.

**“STAT” LED:** As previously described, this LED will blink out the operation mode that the Full Digital Module is operating under. When the board is first powered up, the STAT LED will do the following:

- Light up
- Blink out status code every ten seconds to indicate controller status

**“ALARM” LED:** As previously described, this LED will blink on and off to indicate alarms and diagnostics.

### Other Checks

---

---

---

**NOTE:** The Full Digital Module contains no user-serviceable parts. Contact qualified technical personnel if your module is not operating correctly.

---

---

**OE275-01 Suction Pressure Transducer Testing for R410A Refrigerant**

The Evaporator Coil Temperature is calculated by converting the Suction Pressure to Temperature. The Suction Pressure is obtained by using the OE275-01 Suction Pressure Transducer, which is connected into the Suction Line of the Compressor.

Use the voltage column to check the Suction Pressure Transducer while connected to the Full Digital Module. Read voltage with a meter set on DC volts. If the temperature/voltage or pressure/voltage readings do not align closely with the chart, your Suction Pressure Transducer is probably defective and will need to be replaced.

See the OE275-01 Suction Pressure Transducer, Pressure, Temperature, and Voltage Chart for R410A Refrigerant testing (**Table 4**). The chart shows a temperature range from 20°F to 80°F. For troubleshooting purposes, the DC Voltage readings are also listed with their corresponding temperatures and pressures.

OE275-01 Suction Pressure Transducer Coil Pressure – Temperature – Voltage Chart for R410A Refrigerant					
Temperature °F	Pressure PSI	Signal DC Volts	Temperature °F	Pressure PSI	Signal DC Volts
21.19	80.94	1.8	59.03	168.10	3.2
24.49	87.16	1.9	61.17	174.32	3.3
27.80	93.39	2.0	63.19	180.55	3.4
30.99	99.62	2.1	65.21	186.78	3.5
33.89	105.84	2.2	67.23	193.00	3.6
36.80	112.07	2.3	69.24	199.23	3.7
39.71	118.29	2.4	71.15	205.46	3.8
42.30	124.52	2.5	72.95	211.68	3.9
44.85	130.75	2.6	74.76	217.91	4.0
47.39	136.97	2.7	76.57	224.14	4.1
49.94	143.2	2.8	78.37	230.36	4.2
52.23	149.42	2.9	80.18	236.59	4.3
54.50	155.65	3.0			
56.76	161.88	3.1			

**Table 4: Coil Pressure/Voltage/Temp for OE275-01 Suction Pressure Transducers - R410A Refrigerant**

### VCM-X Modular Controller to Full Digital Module Wiring

When using the VCM-X Modular Controller, the E-BUS Distribution Module is required or connect to the Full Digital Module. The Full Digital Module connects to the E-BUS Distribution Module using a modular HSSC cable. The Full Digital Module requires a 24 VAC power connection with an appropriate VA rating.

The E-BUS Distribution Module connects to the VCM-X Modular Controller, VCM-X Expansion Module, or 12 Relay Expansion Module using the IFC port. See Figure 6 below for wiring.

Any E-BUS module can be connected to each of the four E-BUS Distribution Module's output ports or can be daisy-chained together using HSSC cables.

If using a spliced terminal connection for longer runs, one module can be connected to the E-BUS Distribution Module and any additional modules would be daisy-chained to the first module. For more information, refer to the *E-BUS Distribution Module Technical Guide*.

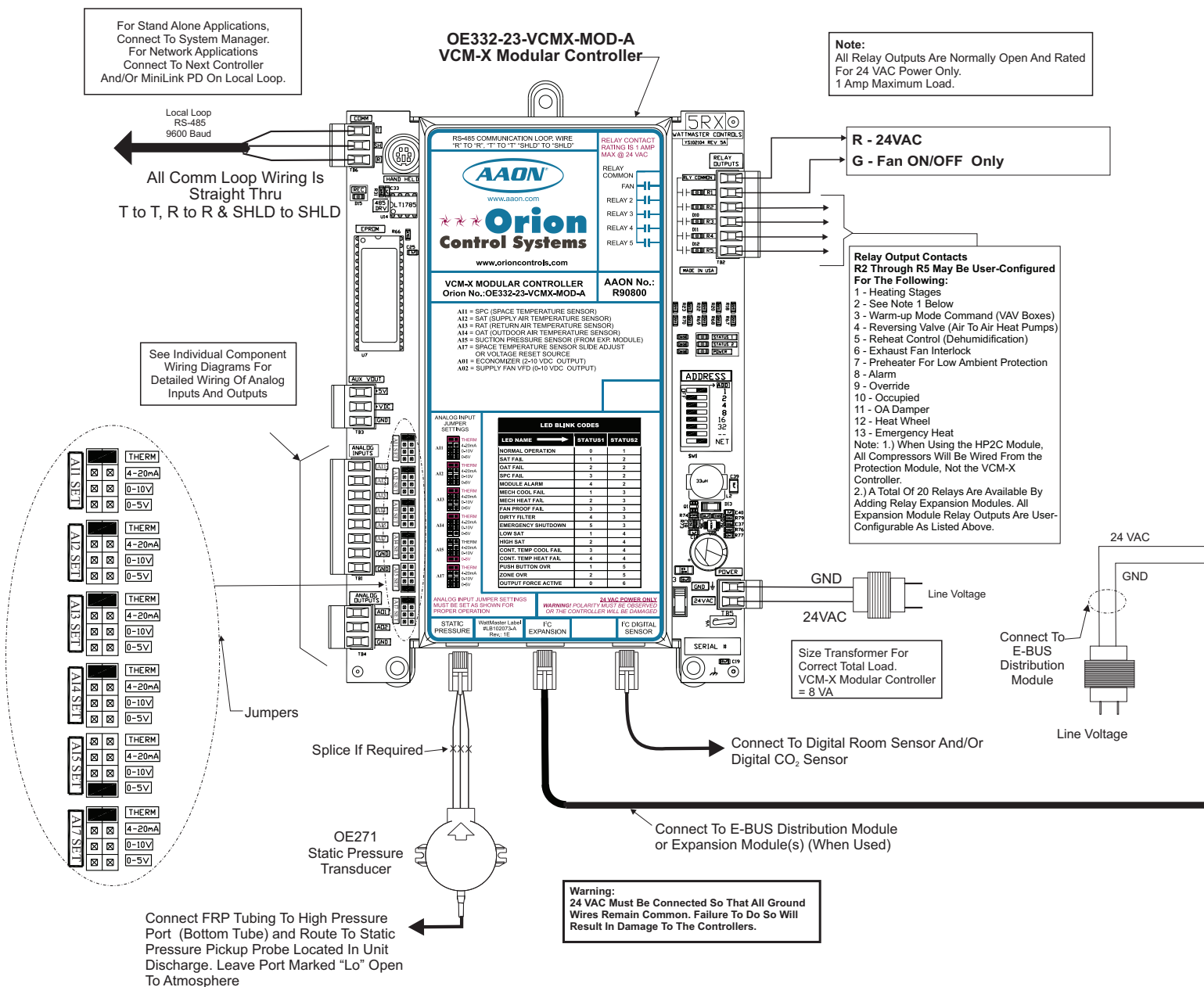

Figure 6: VCM-X Modular Controller Connection to Full Digital Module

**NOTE:** Contact Factory for the correct HSSC cable length for your application. Cables are available in 1/2 and 3 meter lengths and 100 and 150 foot lengths.

**WARNING:** Be sure all controllers and modules are powered down before connecting or disconnecting HSSC cables.

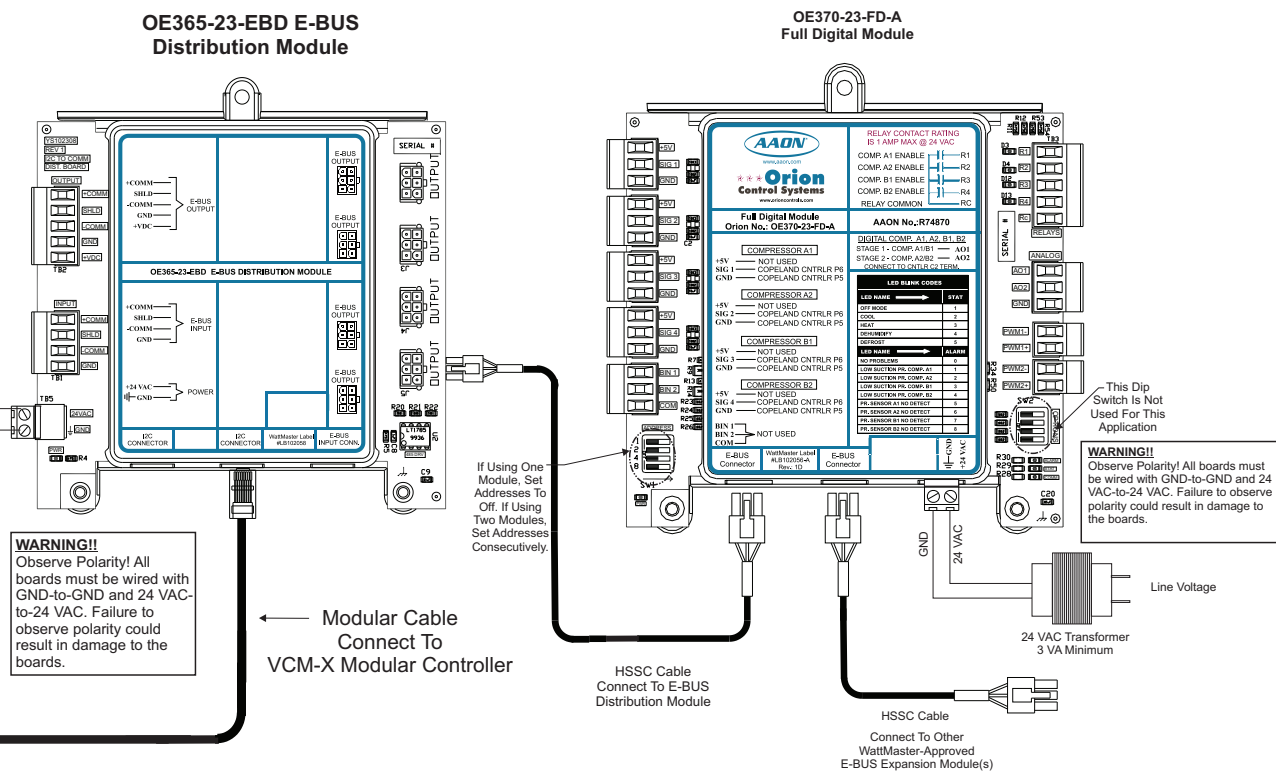

Figure 6: VCM-X Modular Controller Connection to Full Digital Module



**[www.aaon.com](http://www.aaon.com)**

2425 So. Yukon Ave • Tulsa, OK 74107-2728  
Ph: (918) 583-2266 • Fax: (918) 583-6094  
AAON® Manual Part No. R84500  
WattMaster Manual Form No: AA-FDM-TGD-01G

---